









REMINISCENCE:









# THE MUZONIA DEPTHS









**PUDRUK**  
LEGO BUILDING  
INSTRUCTIONS



# PARTS REQUIRED

	Technic, Axle Connector 2 x 3 with Ball Socket, Open Sides 32174 Orange	5
	Bionicle Foot Wedge 3 x 7 x 3 32560 Flat Silver	2
	Technic, Axle Connector 2 x 3 with Ball Socket, Open Sides 32174 Dark Blue	2
	Technic, Axle and Pin Connector 2 x 5 with Two Ball Joint Sockets, Closed Sides 61053 Black	1
	Bionicle Ball Joint 3 x 3 x 2 90 Degree with 2 Ball Joints and Axle Hole 47300 Dark Bluish Gray	4
	Bar 1L with Clip Mechanical Claw 48729 Black	3
	Bar 3L (Bar Arrow) 87994 Black	2

	Technic, Liftarm 1 x 3 Thin 6632 Black	2
	Pneumatic T Piece Second Version (T Bar with Ball in Center) 4697b Black	3
	Technic, Liftarm 1 x 2 Thick with Pin Hole and Axle Hole 60483 Black	1
	Bionicle Foot Small with Axle Connector 87791 Black	1
	Plant Brick, Round 1 x 1 with 3 Bamboo Leaves 30176 Lime	2
	Barb / Claw / Horn - Small 53451 Lime	8
	Bar Holder with Clip 11090 Black	8
	Technic, Axle 3 4519 Black	2

	Technic, Axle 9 60485 Light Bluish Gray	1
	Technic, Axle Connector Hub with Two Bar Holders (Lightsaber Hilt) 24122 Dark Bluish Gray	1
	Technic, Axle Pin without Friction Ridges Lengthwise 3749 Black	2
	Technic, Pin 1/2 4274 Light Bluish Gray	1
	Plant Leaves 6 x 5 Swordleaf with Clip 30239 Lime	1
	Bionicle Vahki Leg Lower Section 47328 Dark Blue	1
	Bionicle Head Connector Block (Glatorian) 64262 Trans-Neon Orange	1
	Minifigure, Weapon Sword, Spike Flexible 3.5L with Pin 64727 Light Bluish Gray	2

1

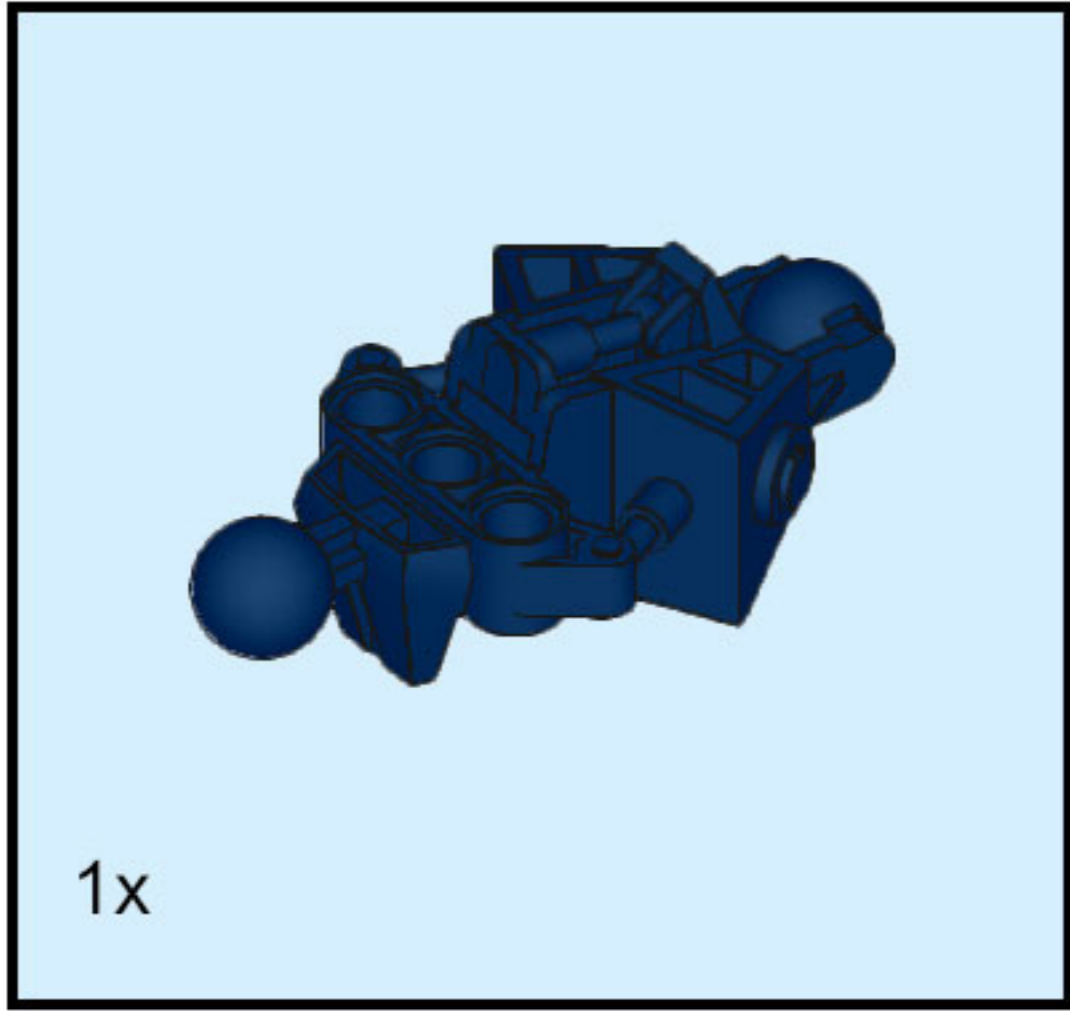

2

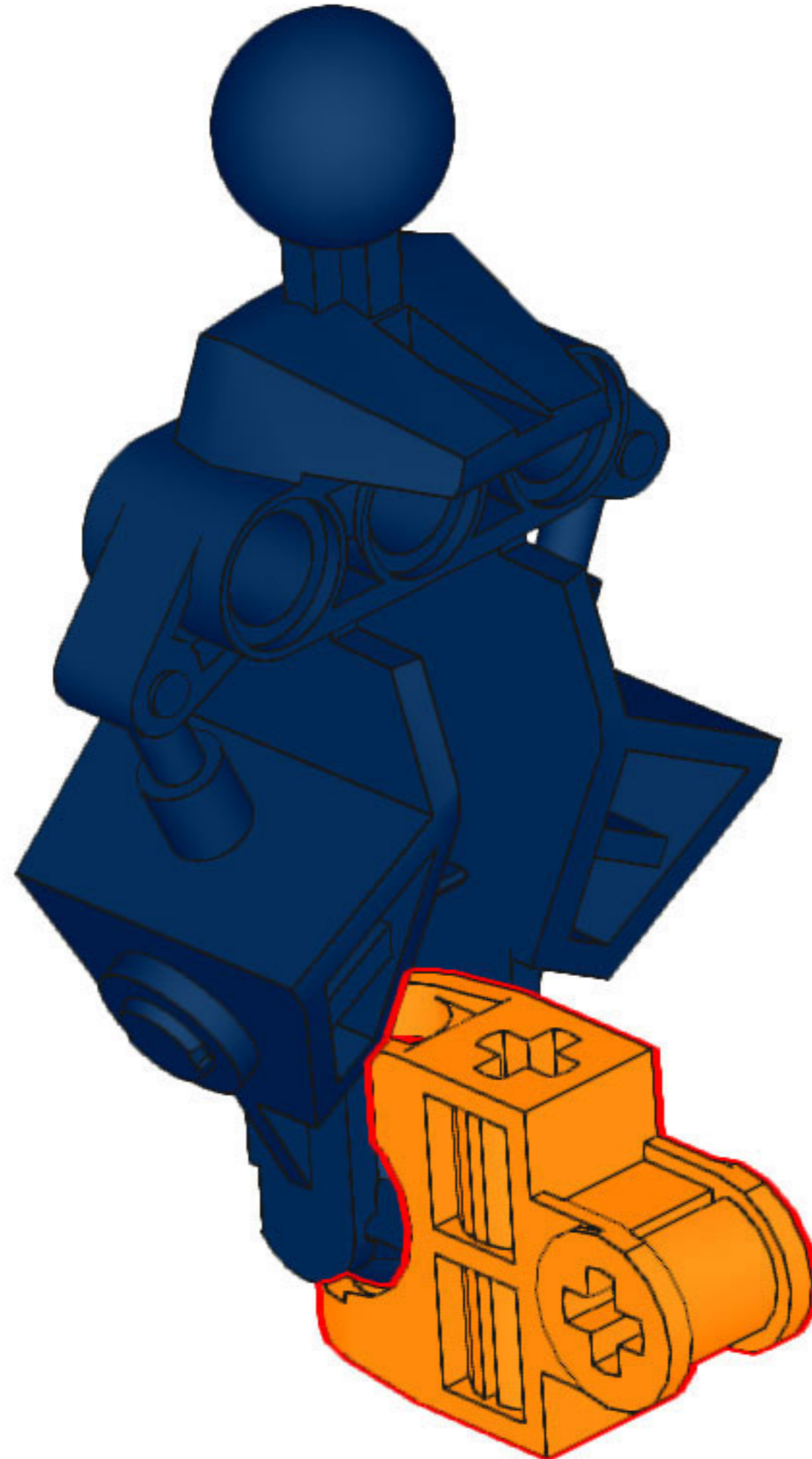
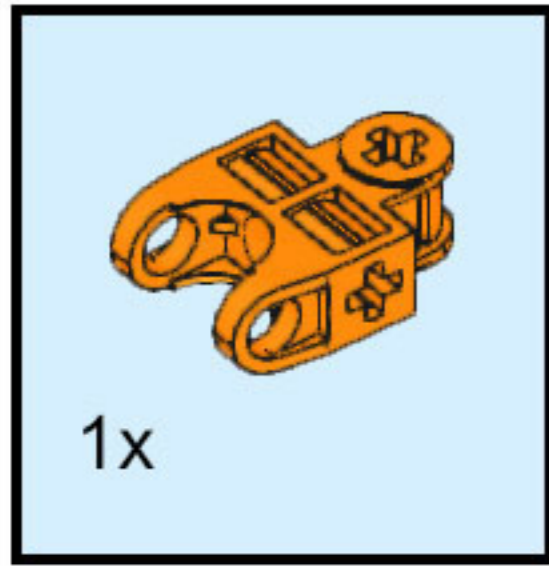

3

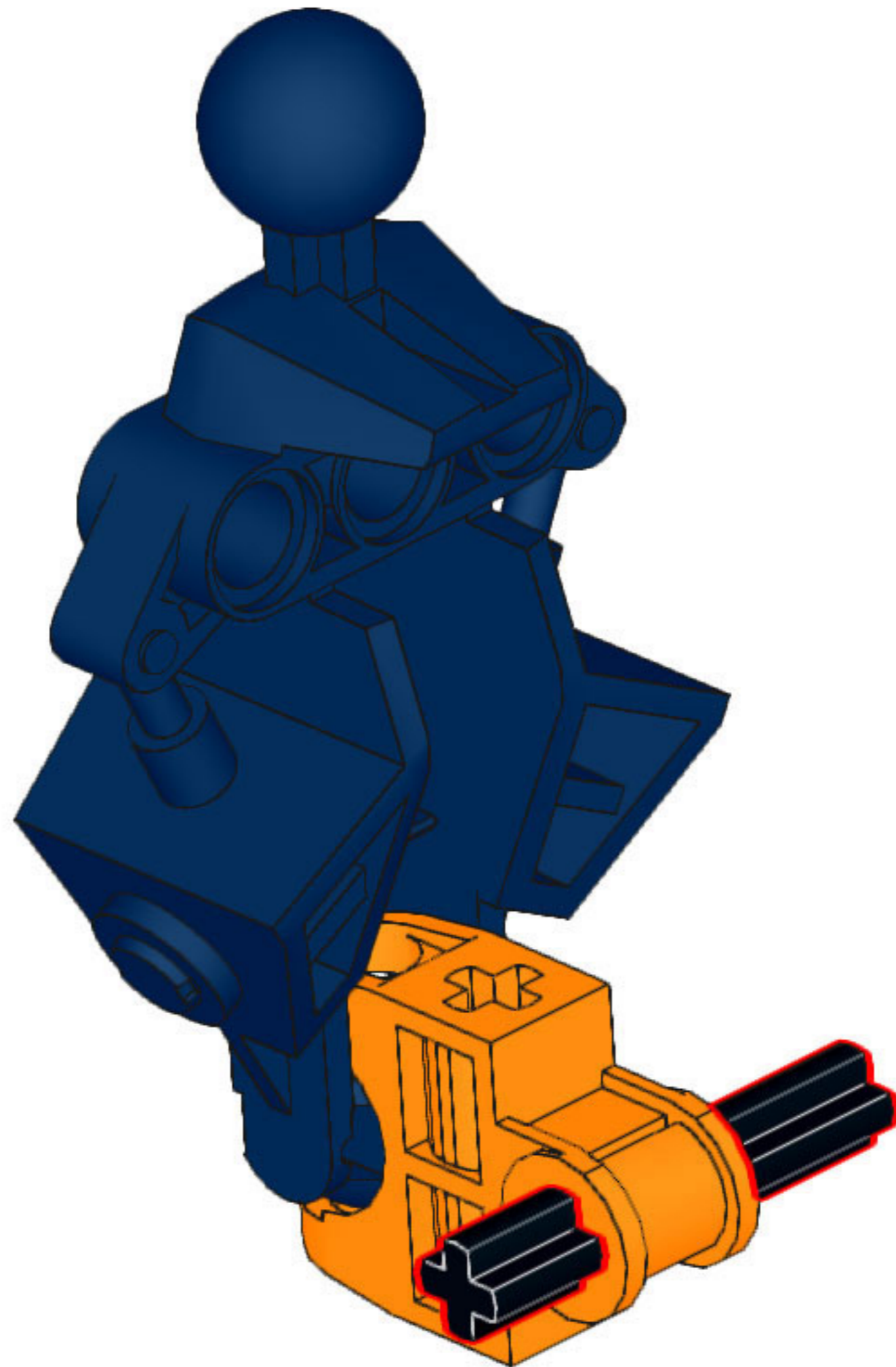
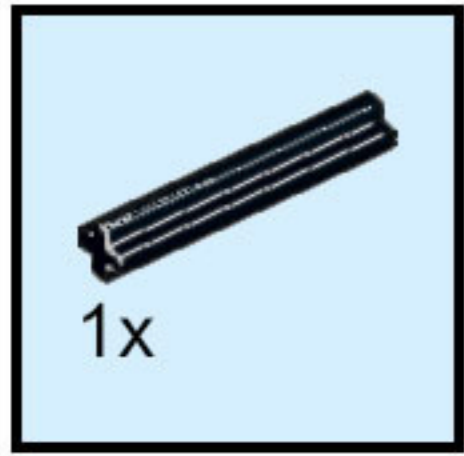

4

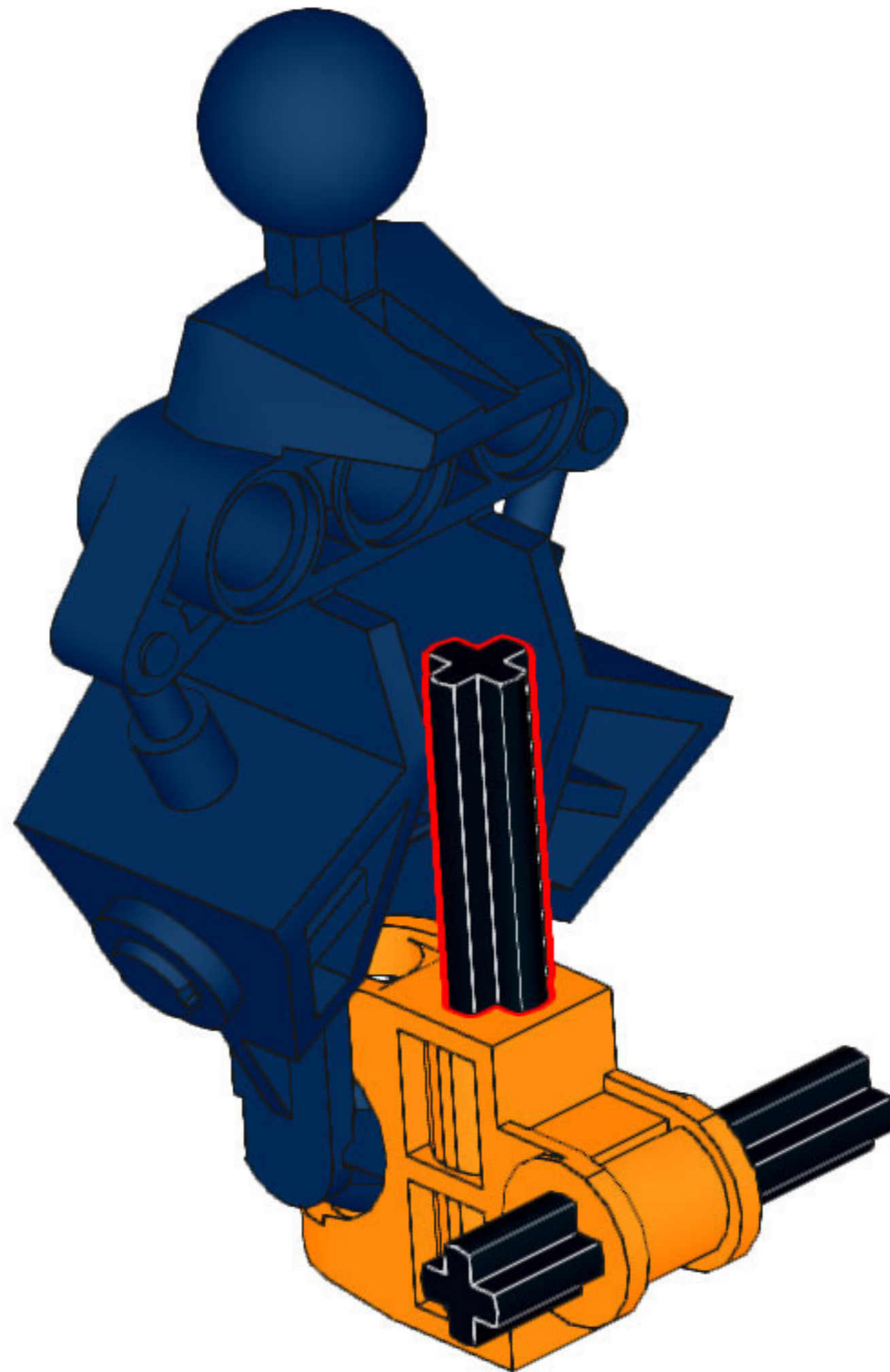
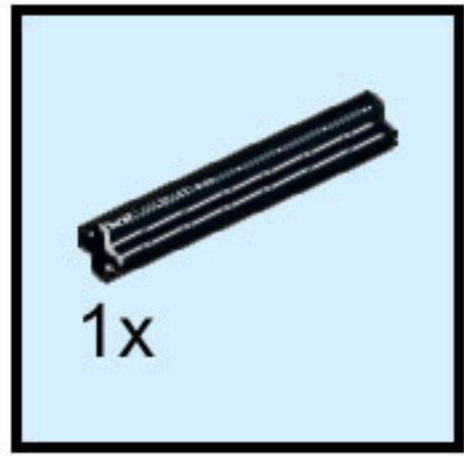

5

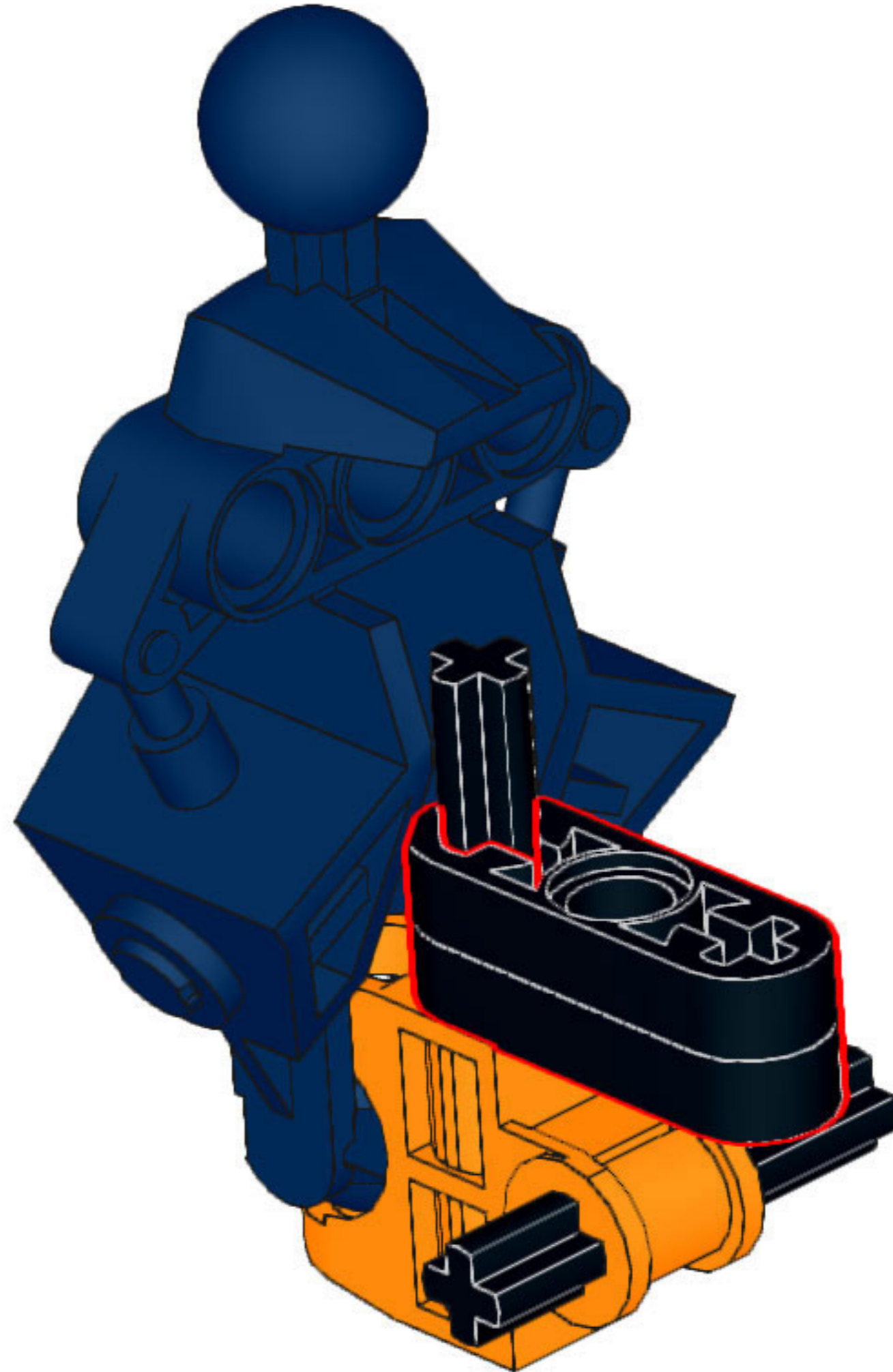

6

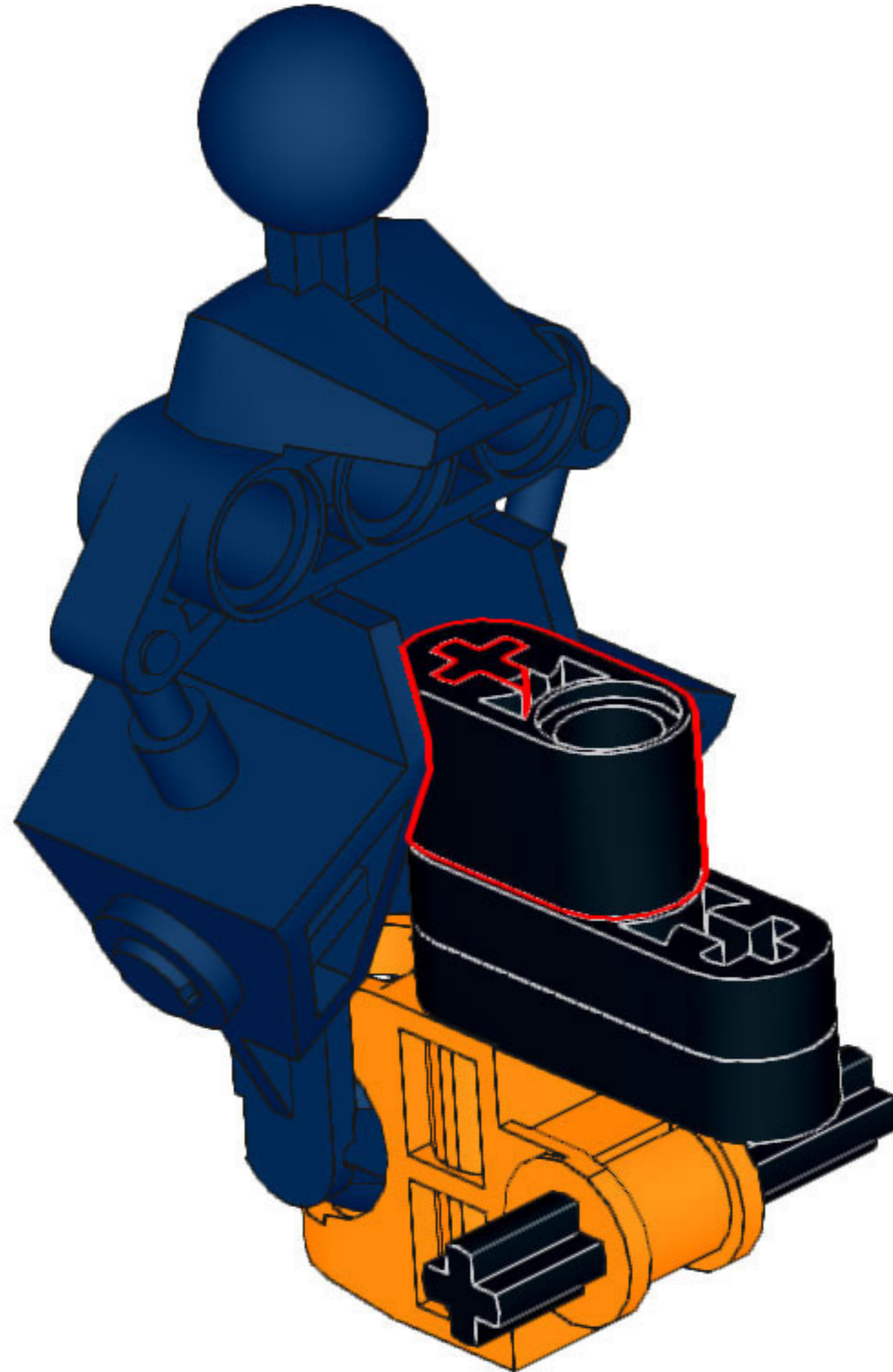
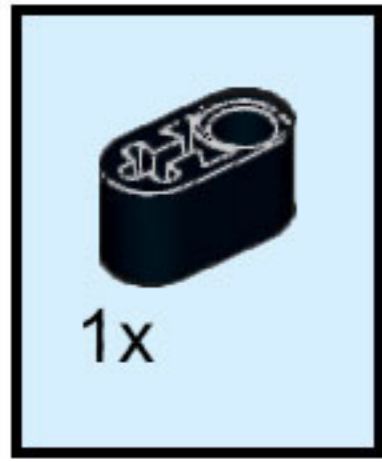

7

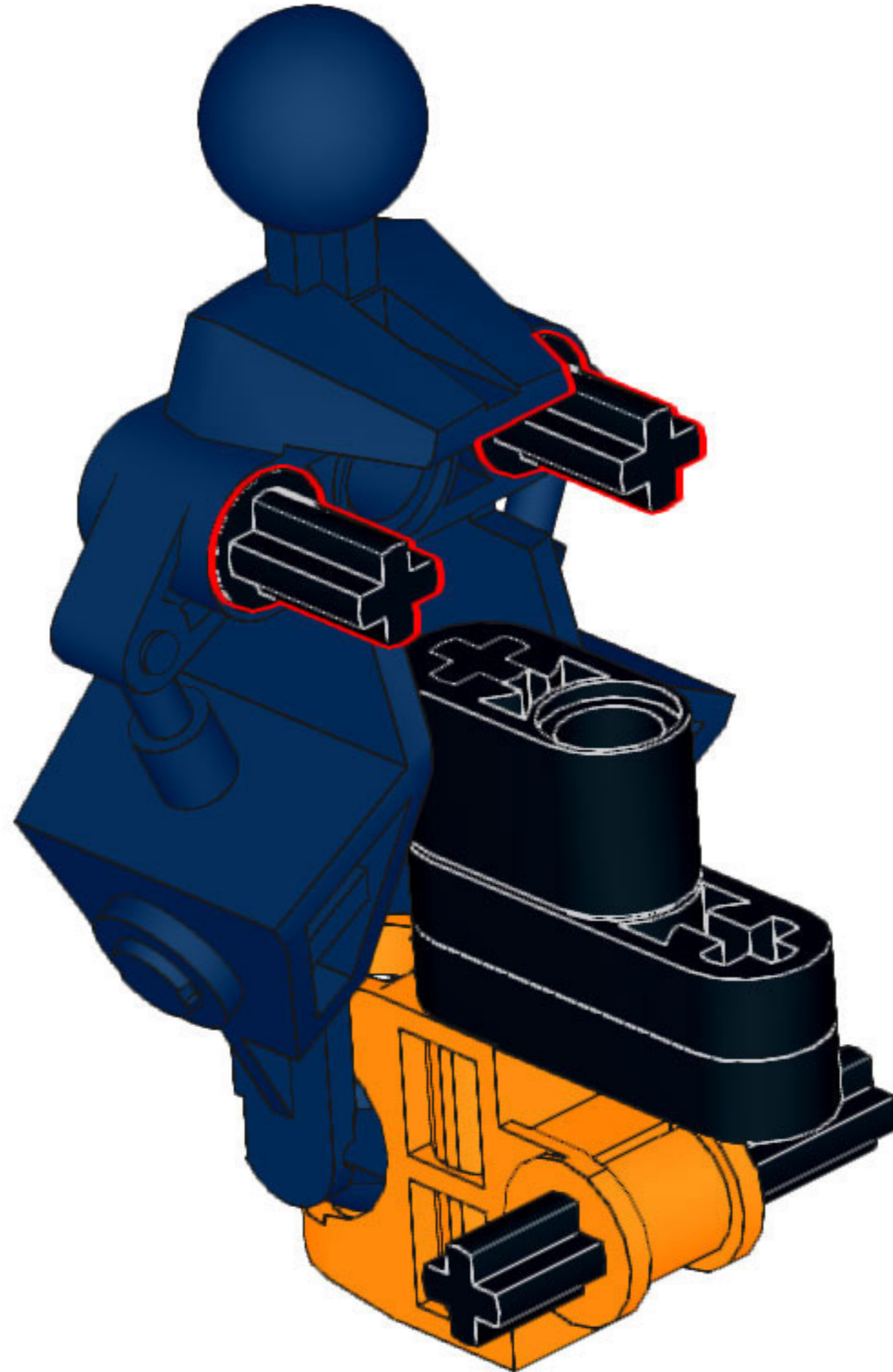

8

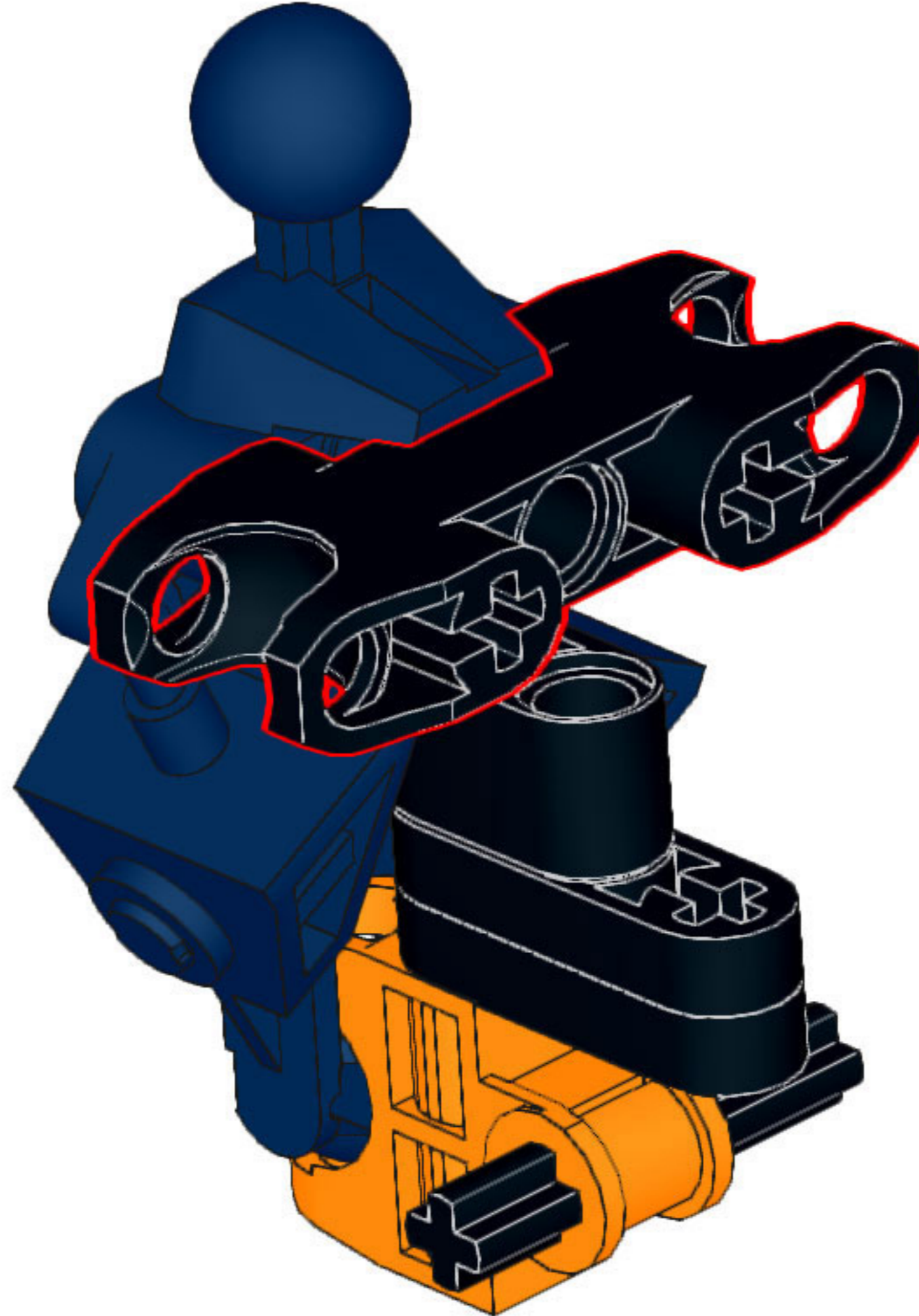
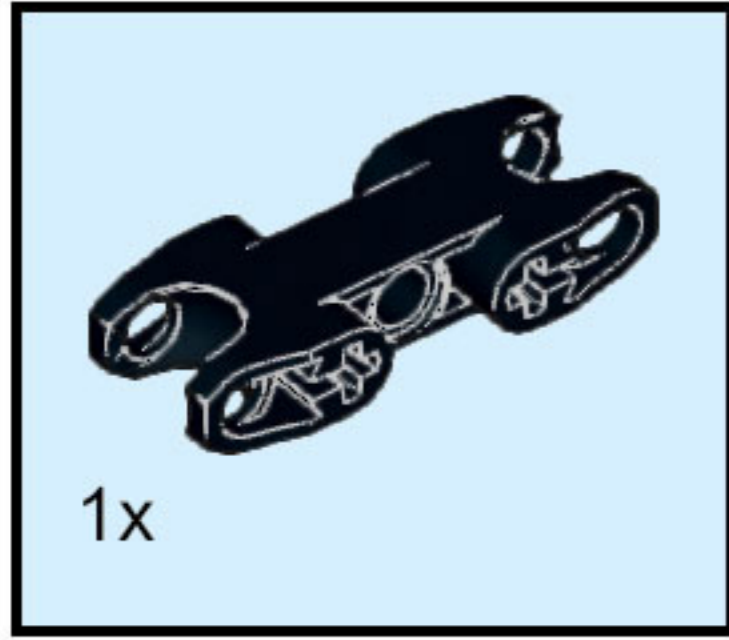

9

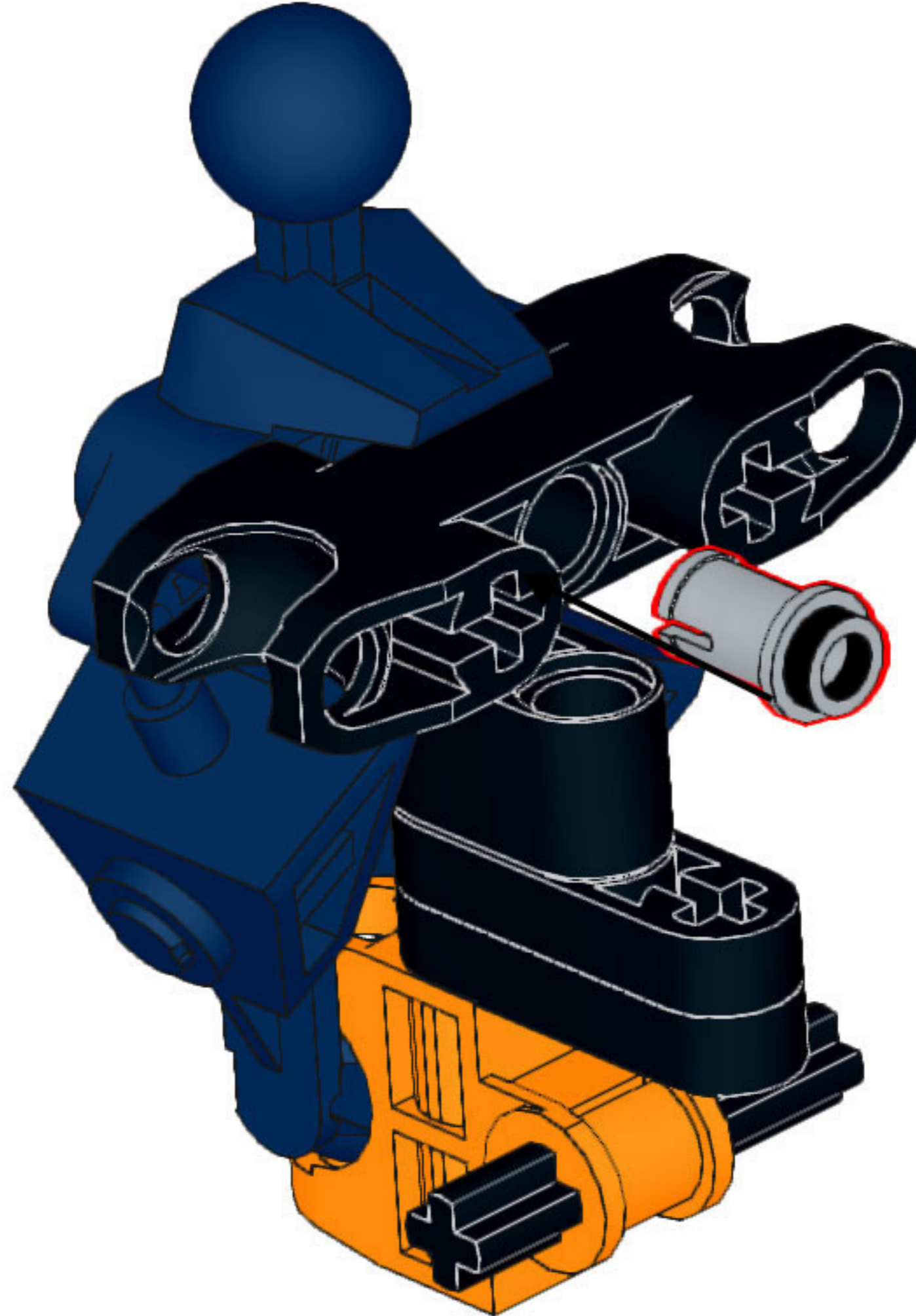
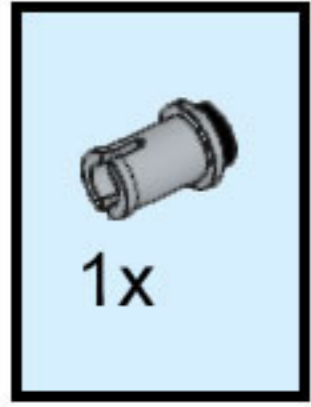

# 10

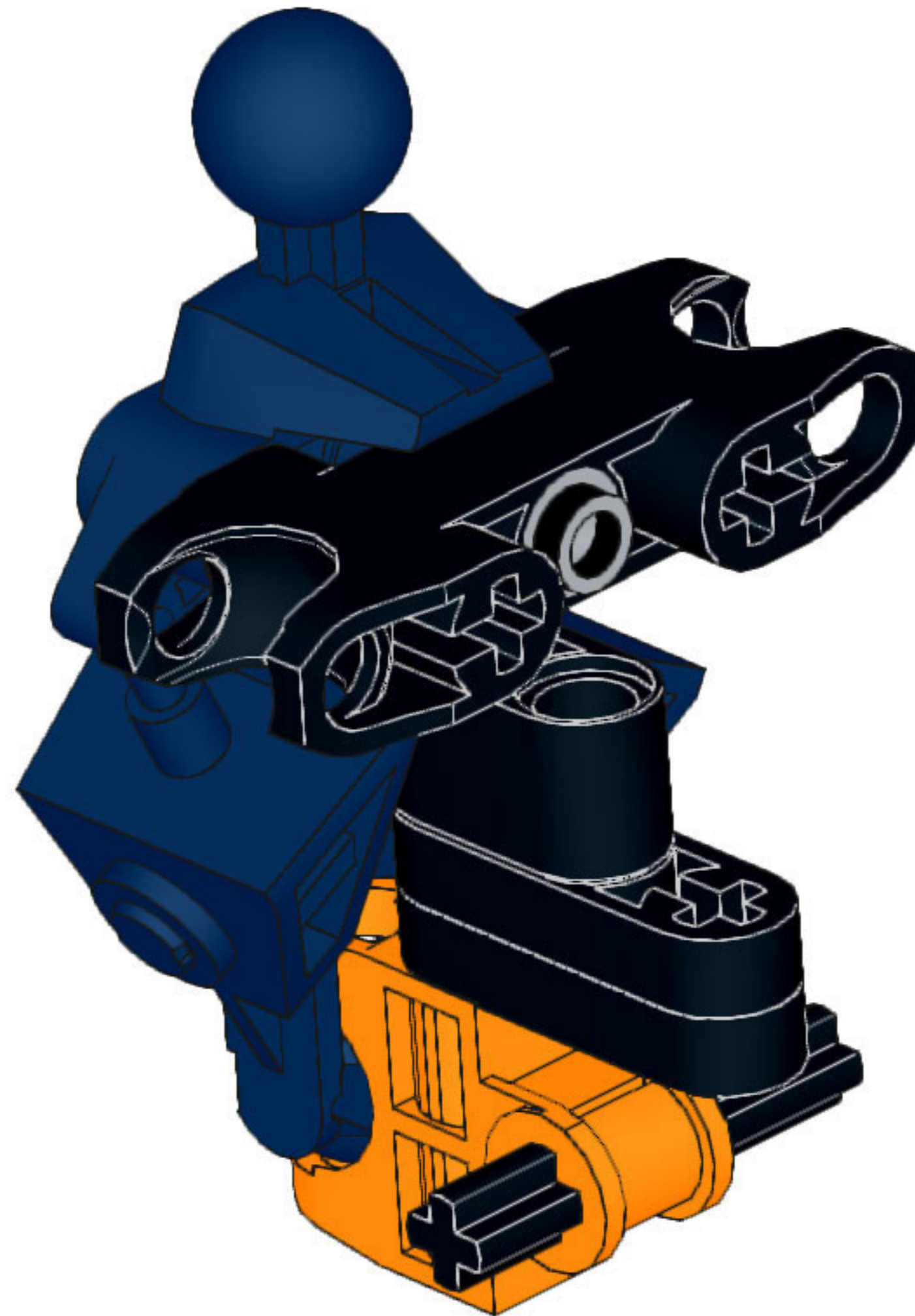

11

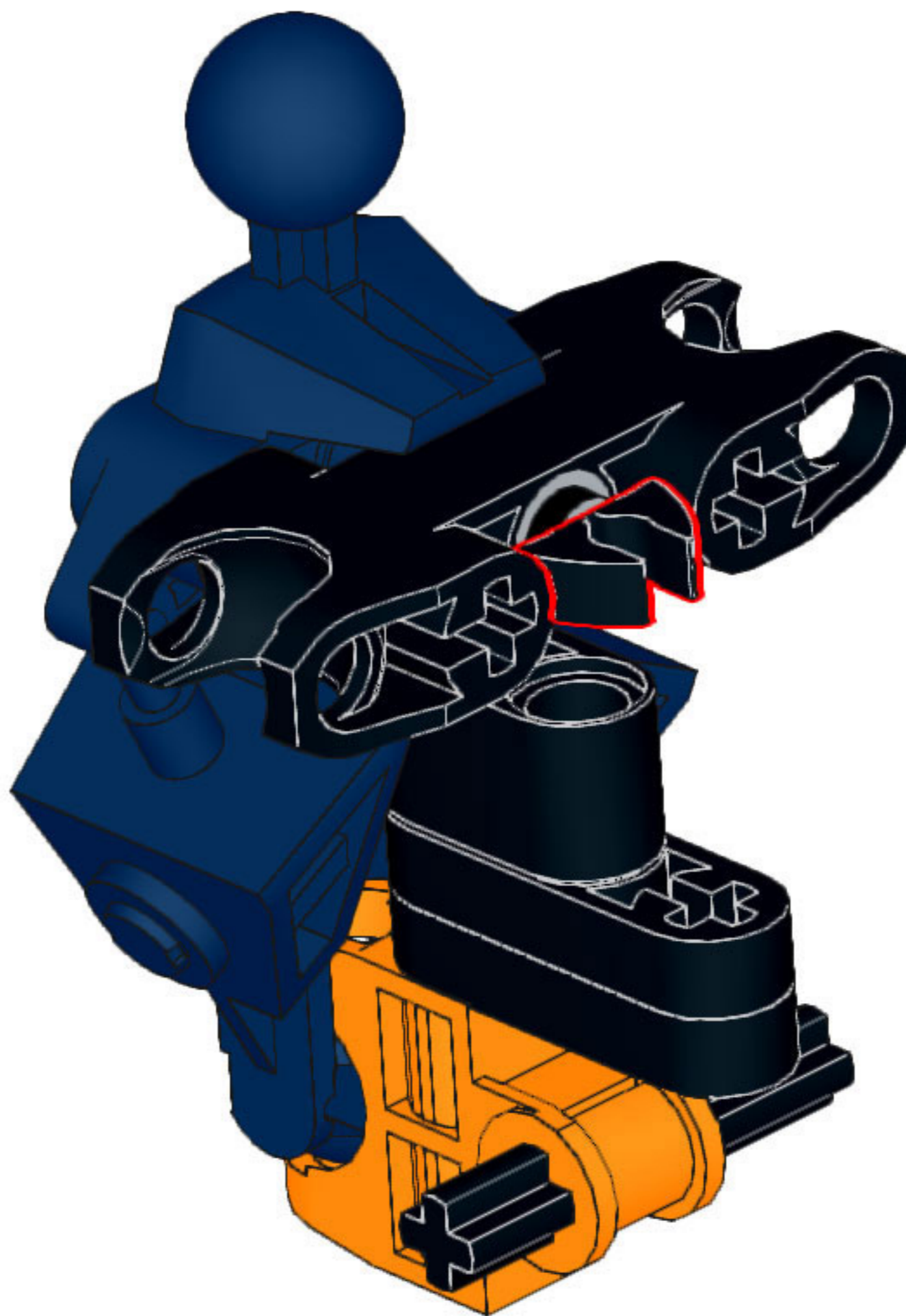

# 12

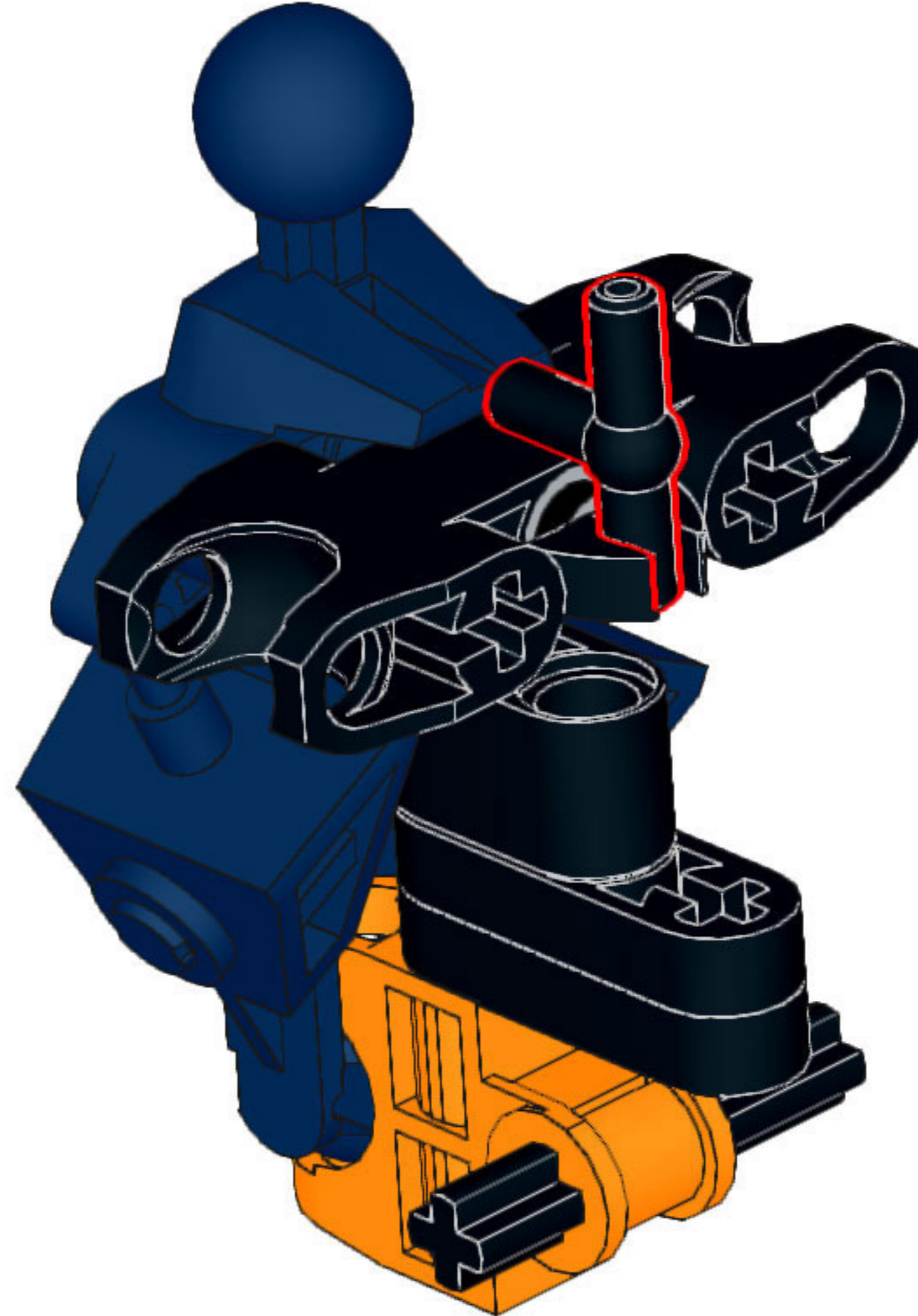
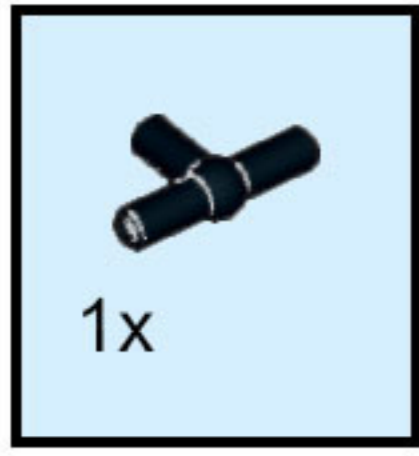

# 13

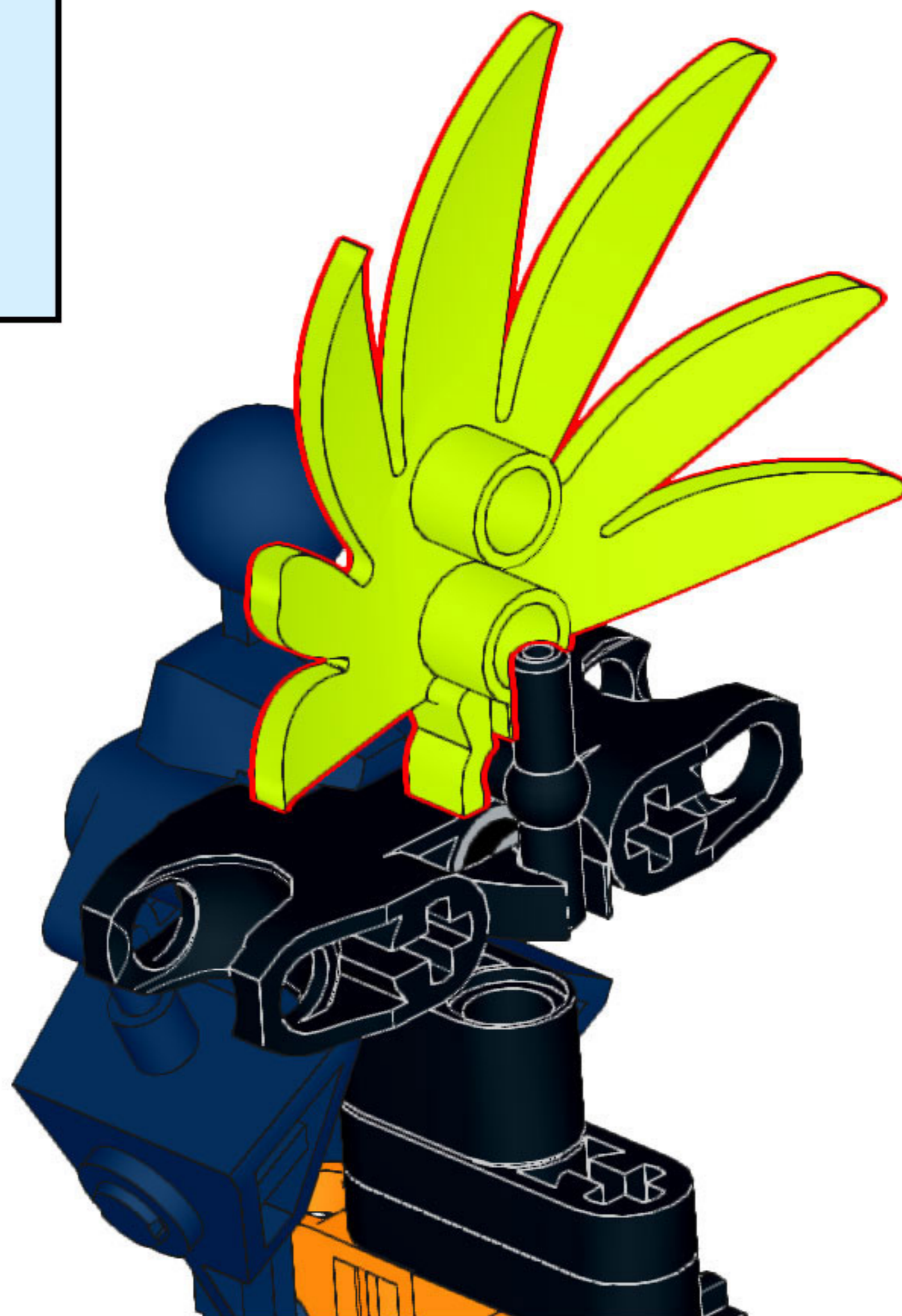
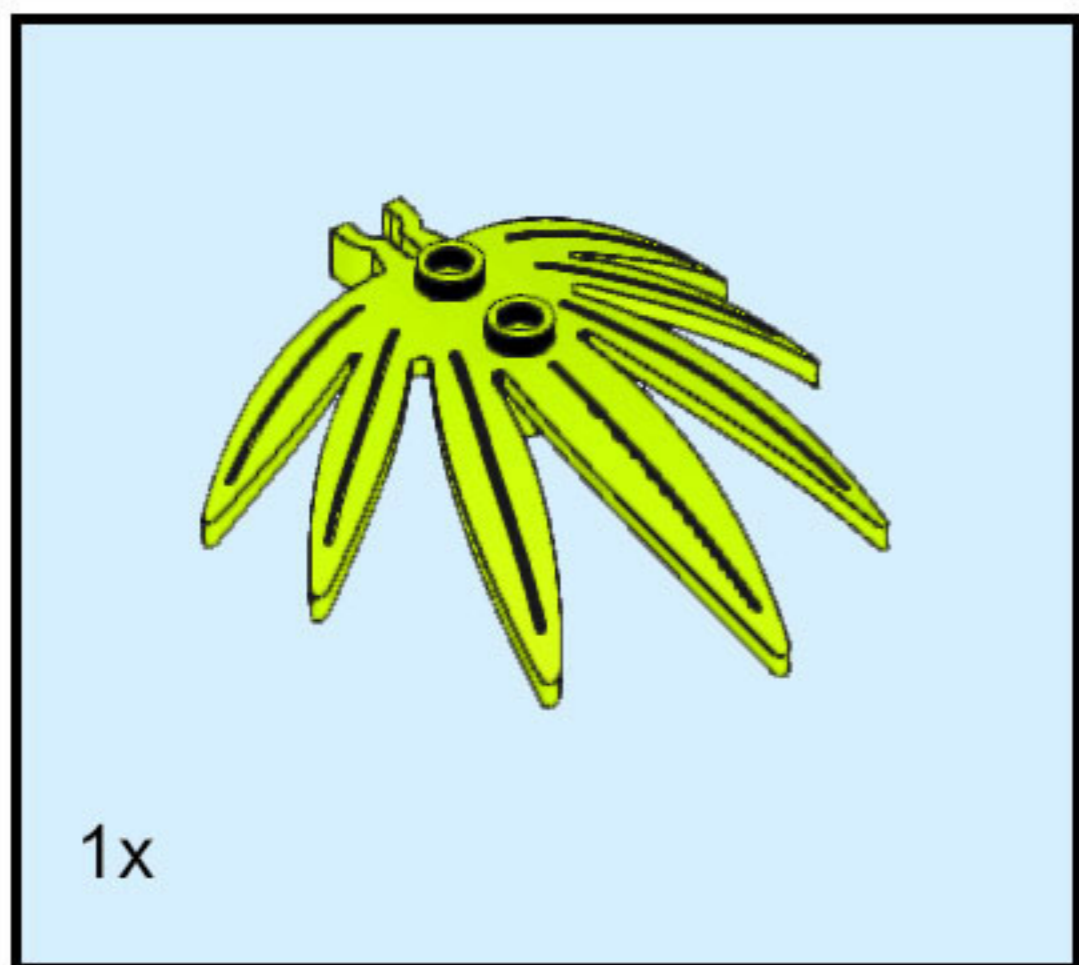

14

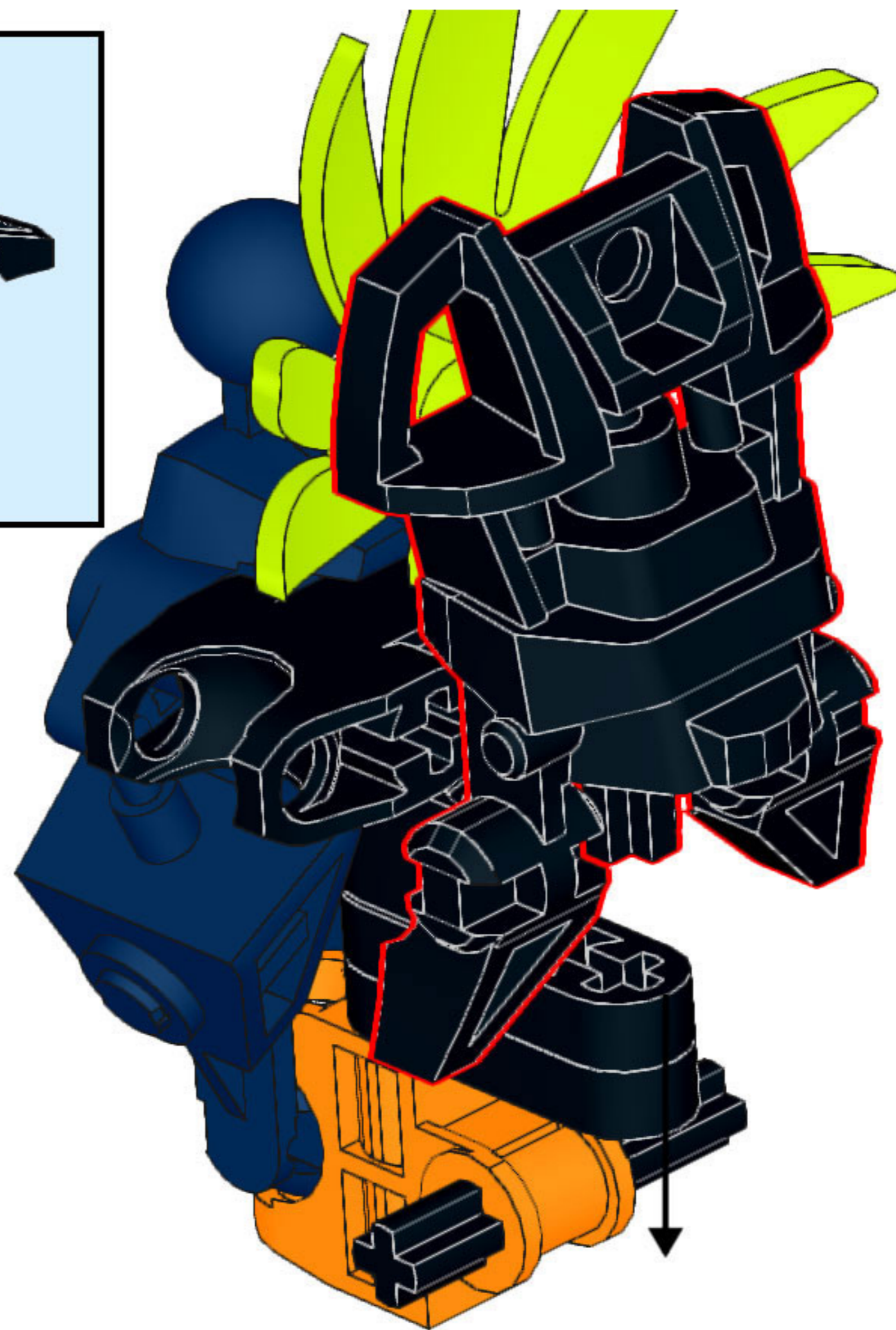
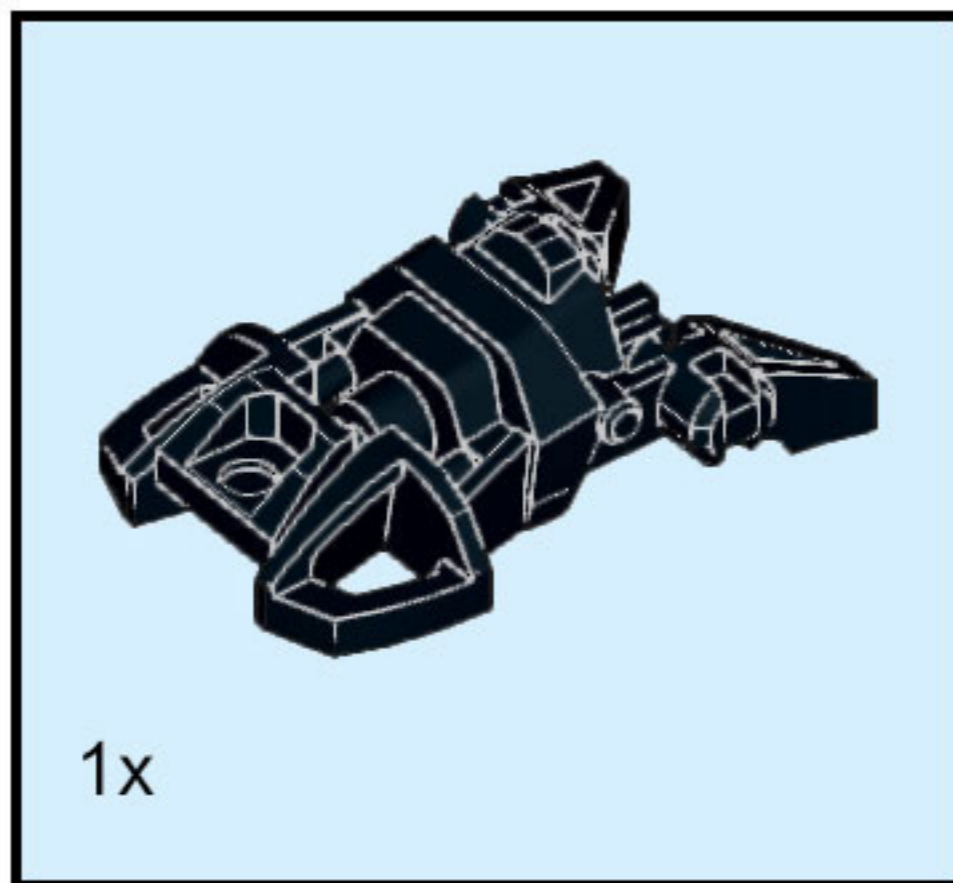

# 15



# 16

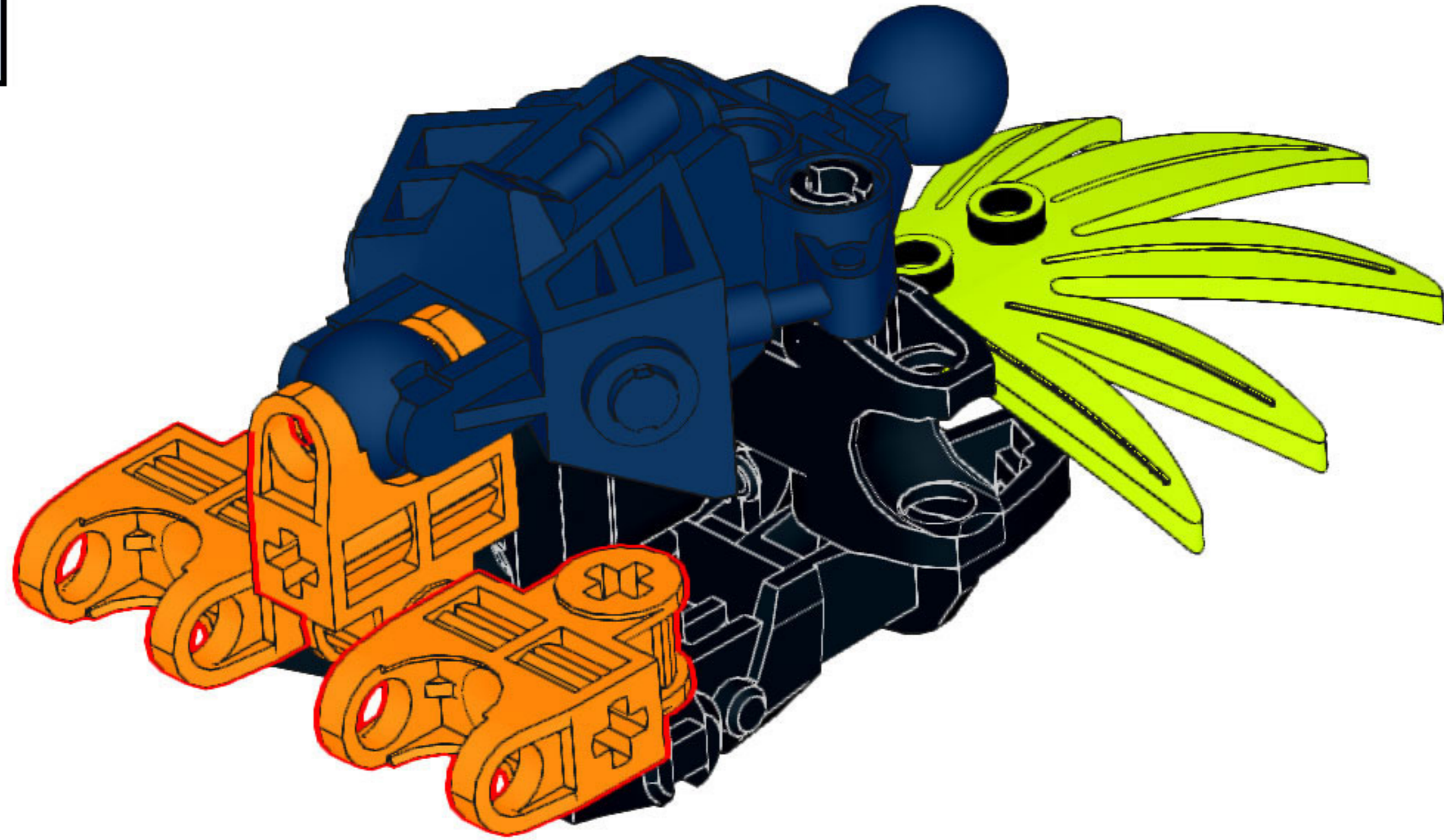
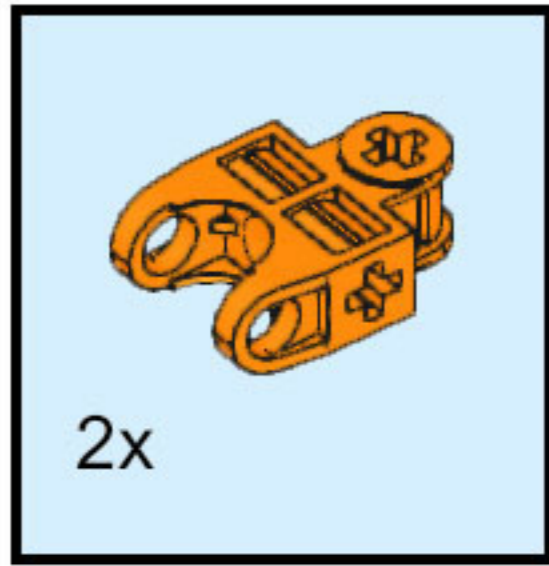

# 17

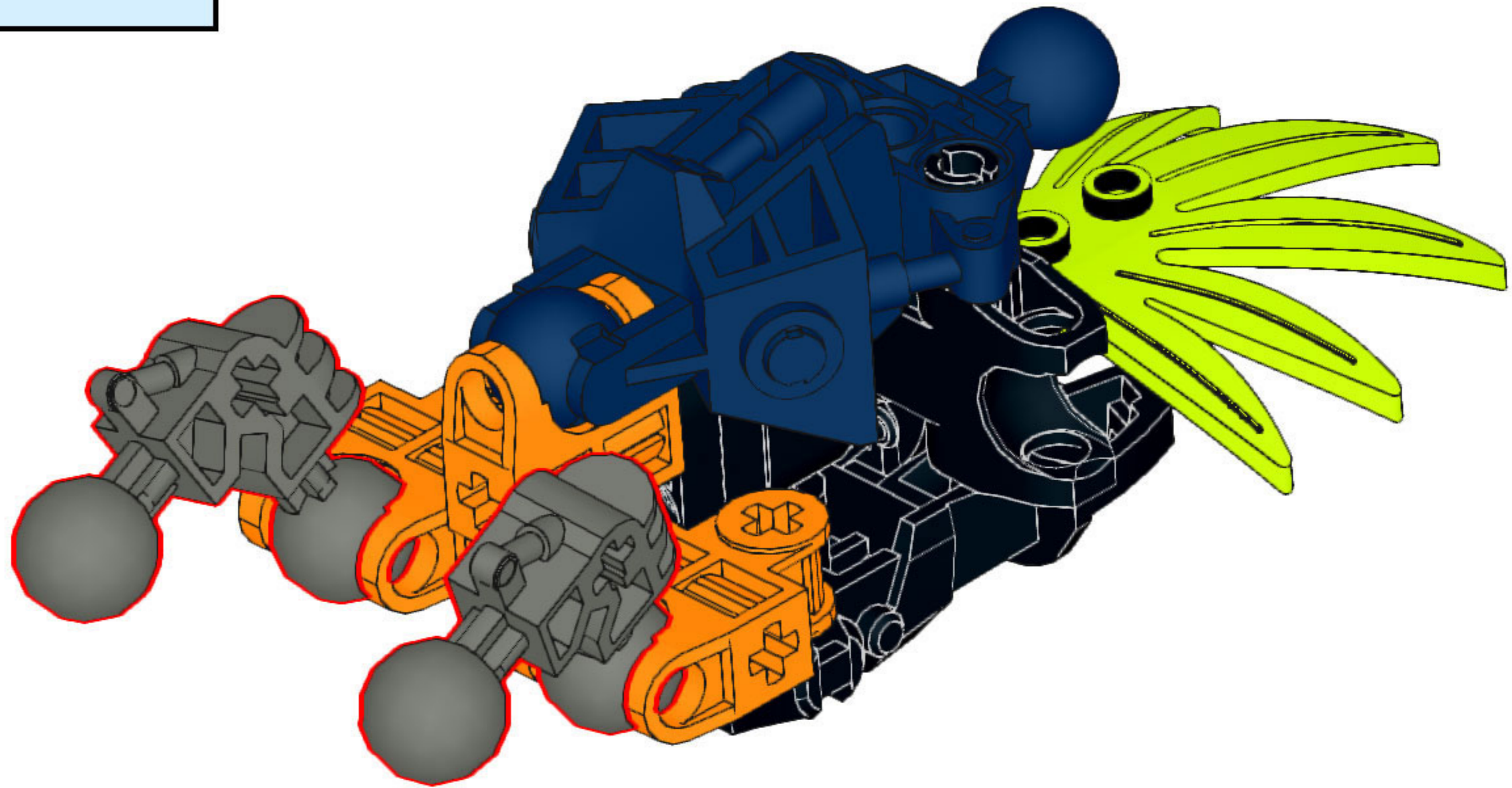
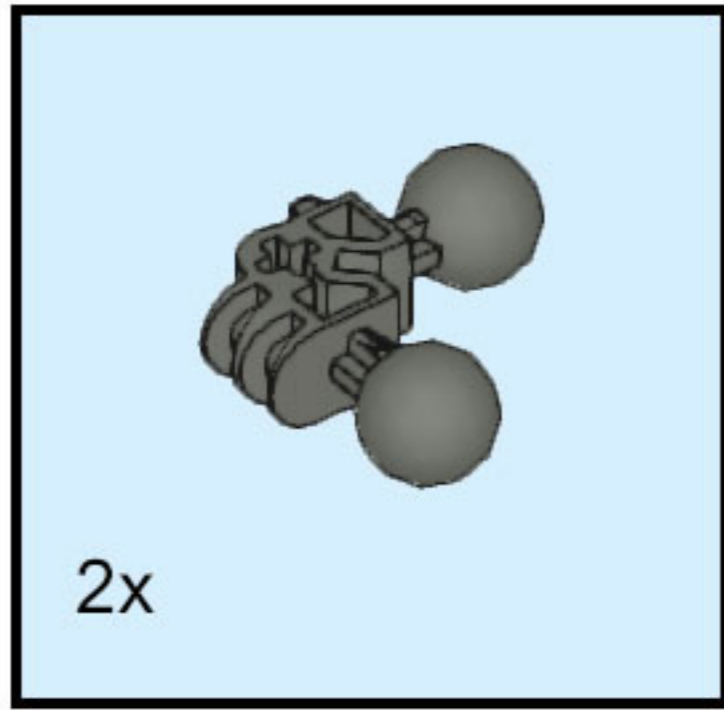

# 18

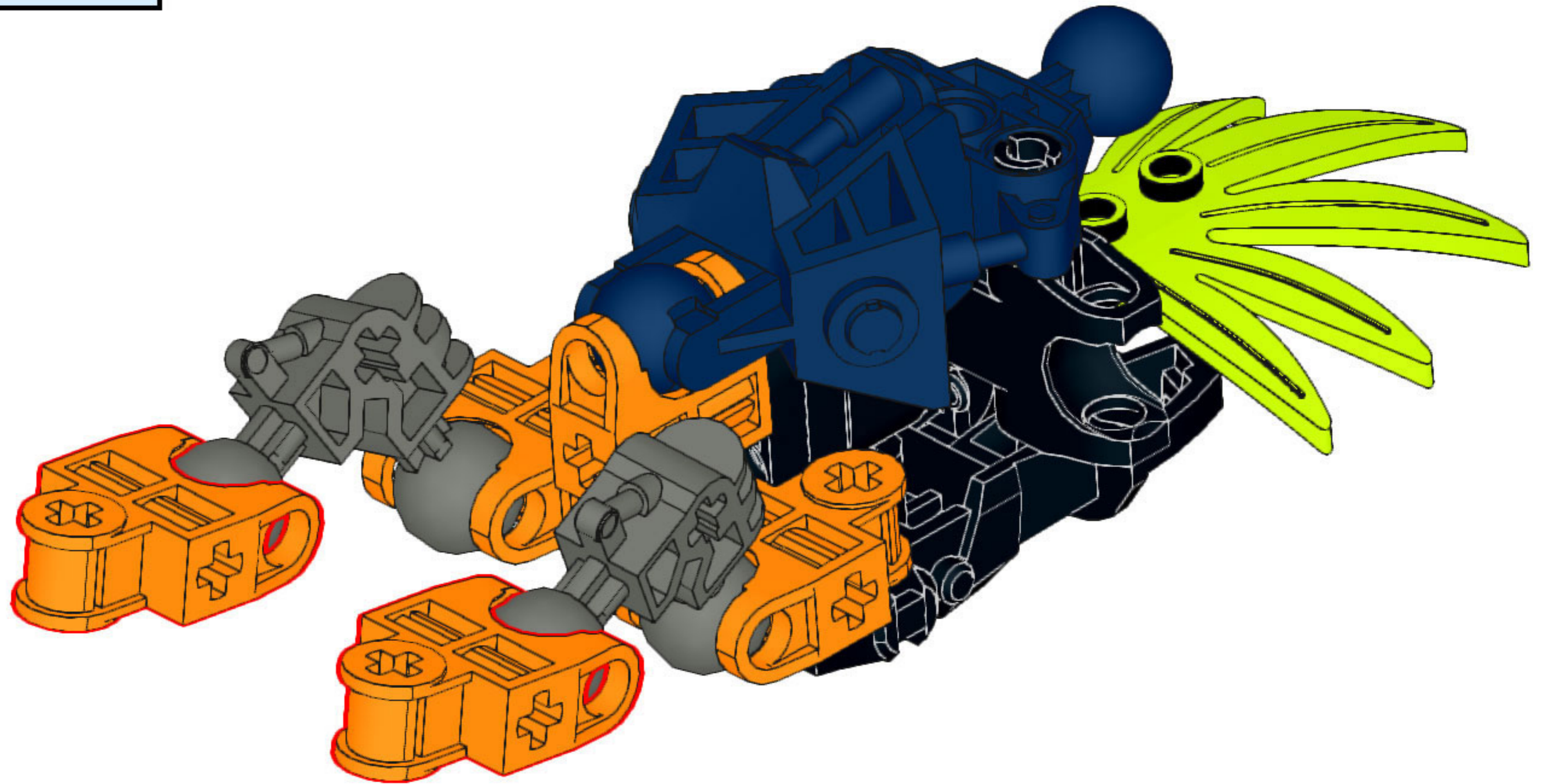
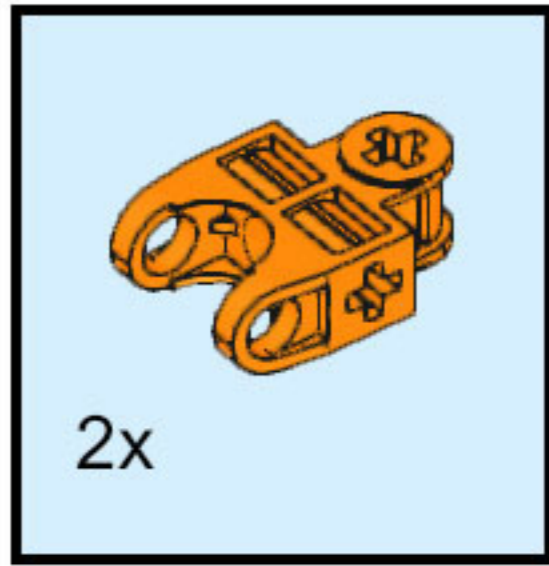



20

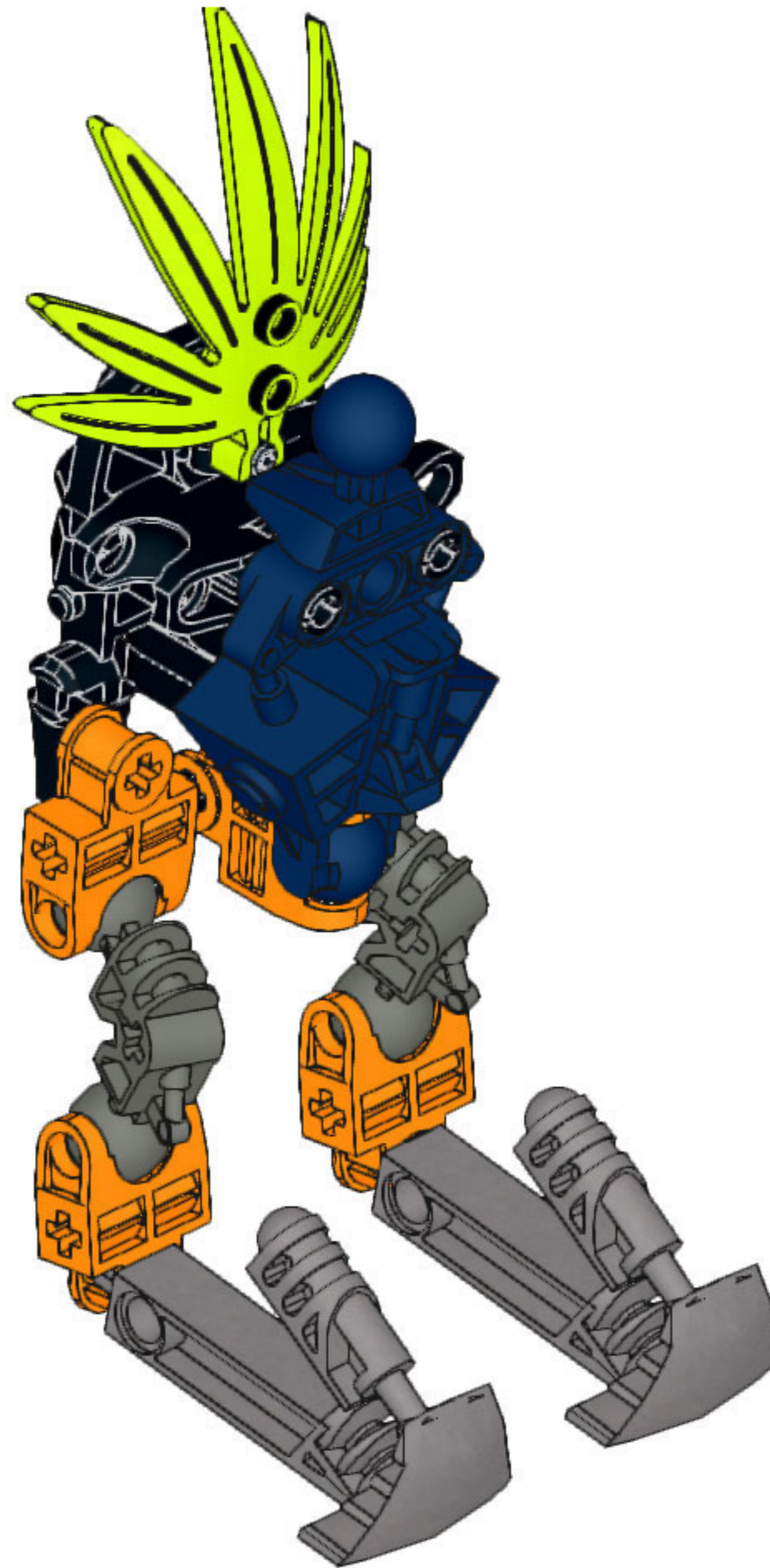

# 21

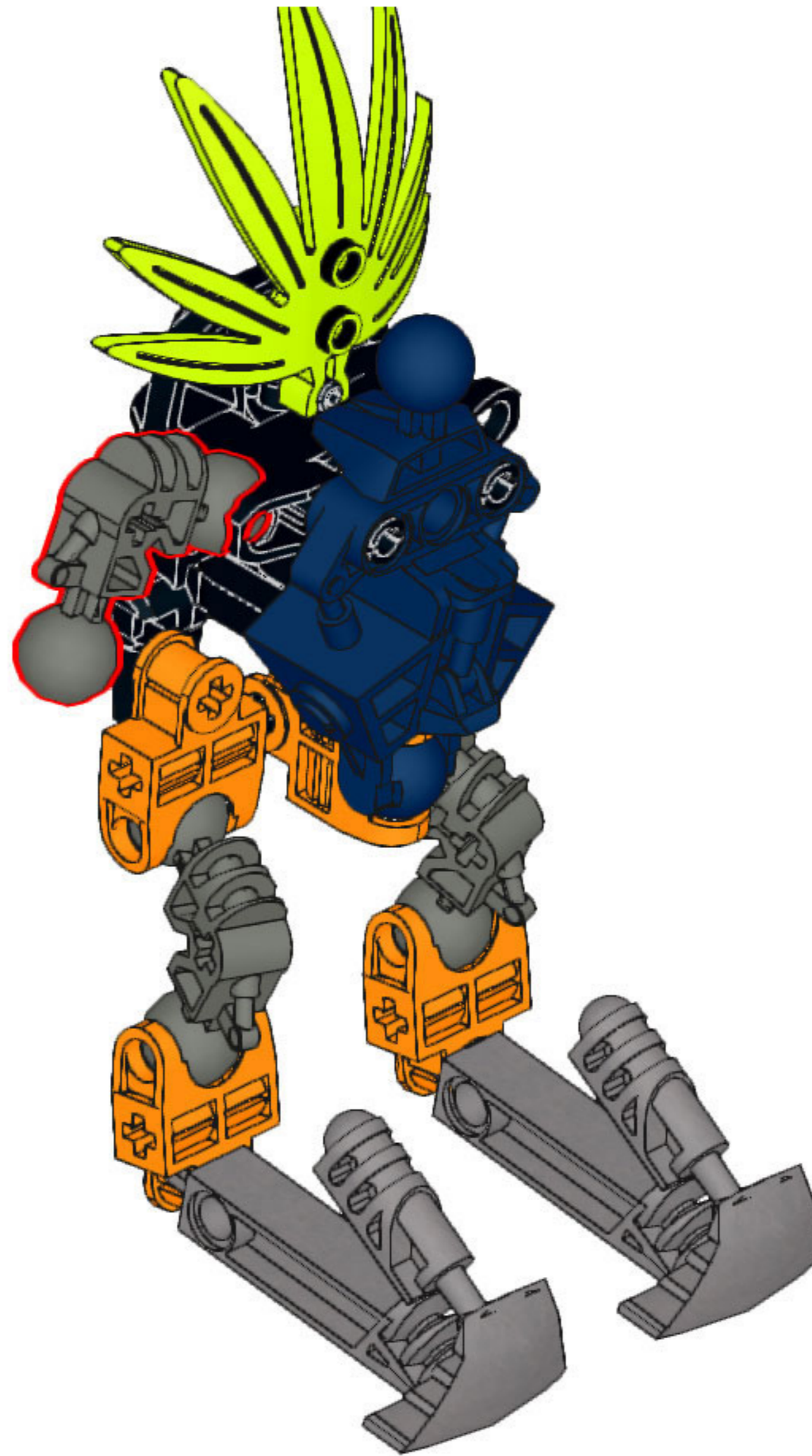
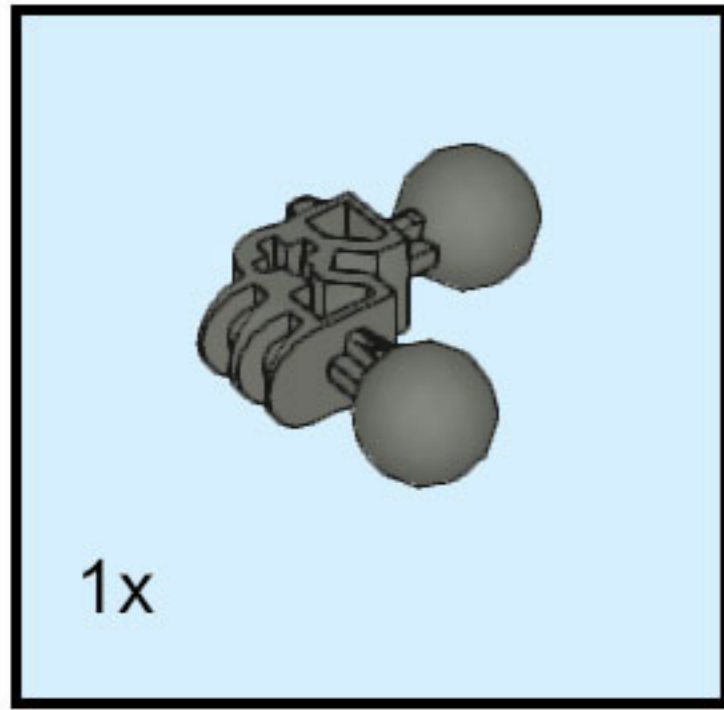

22

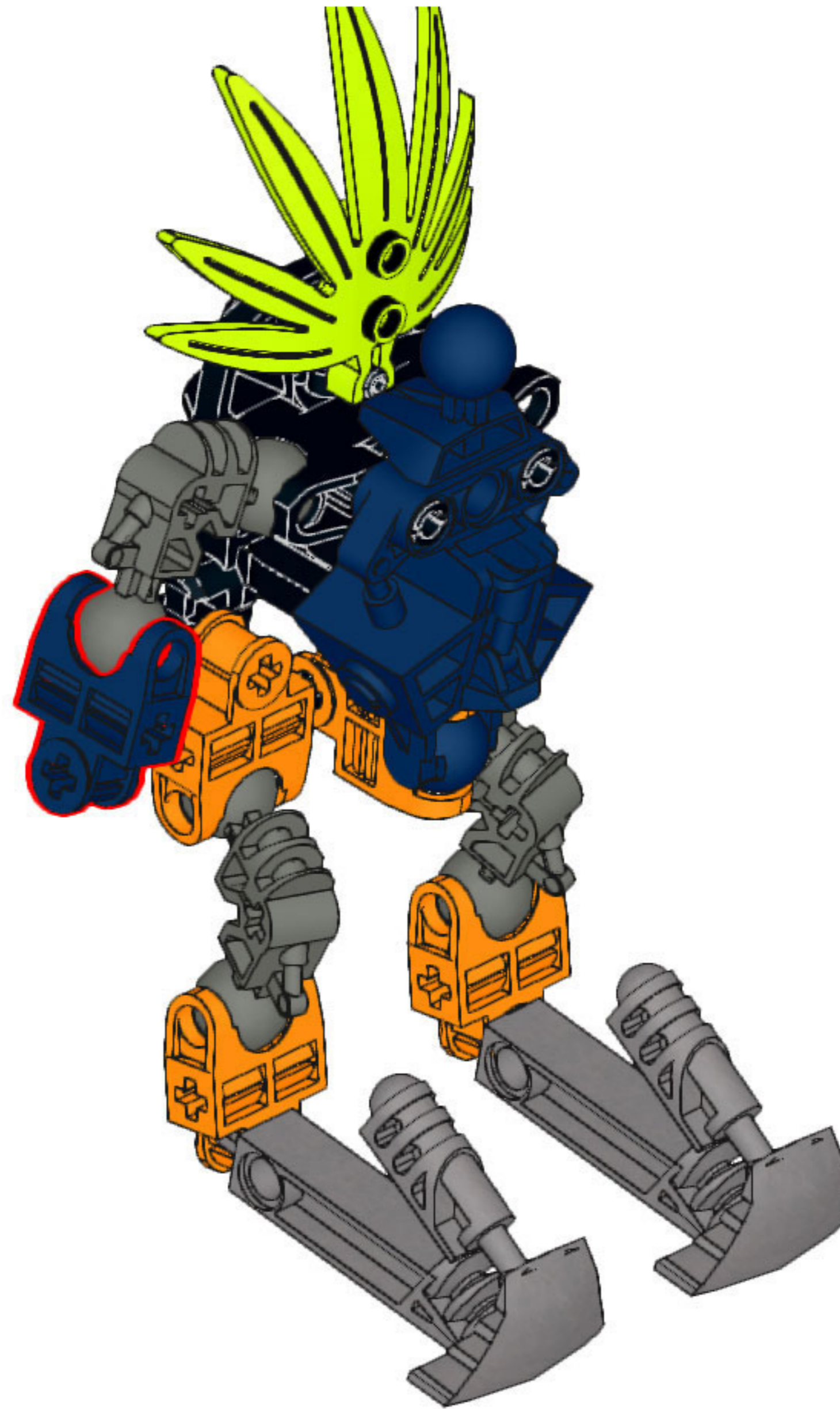
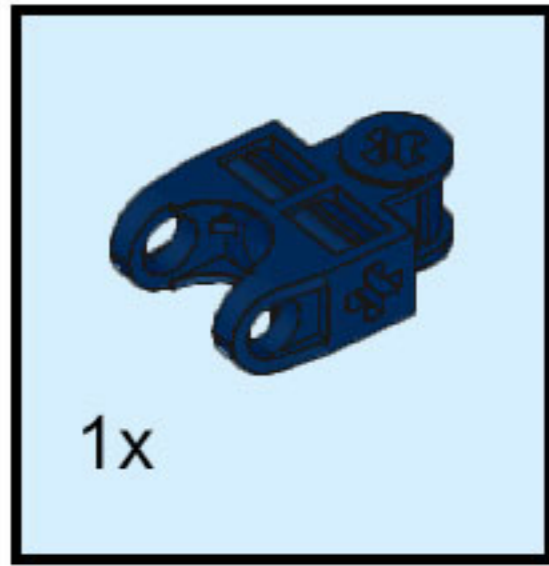

# 23

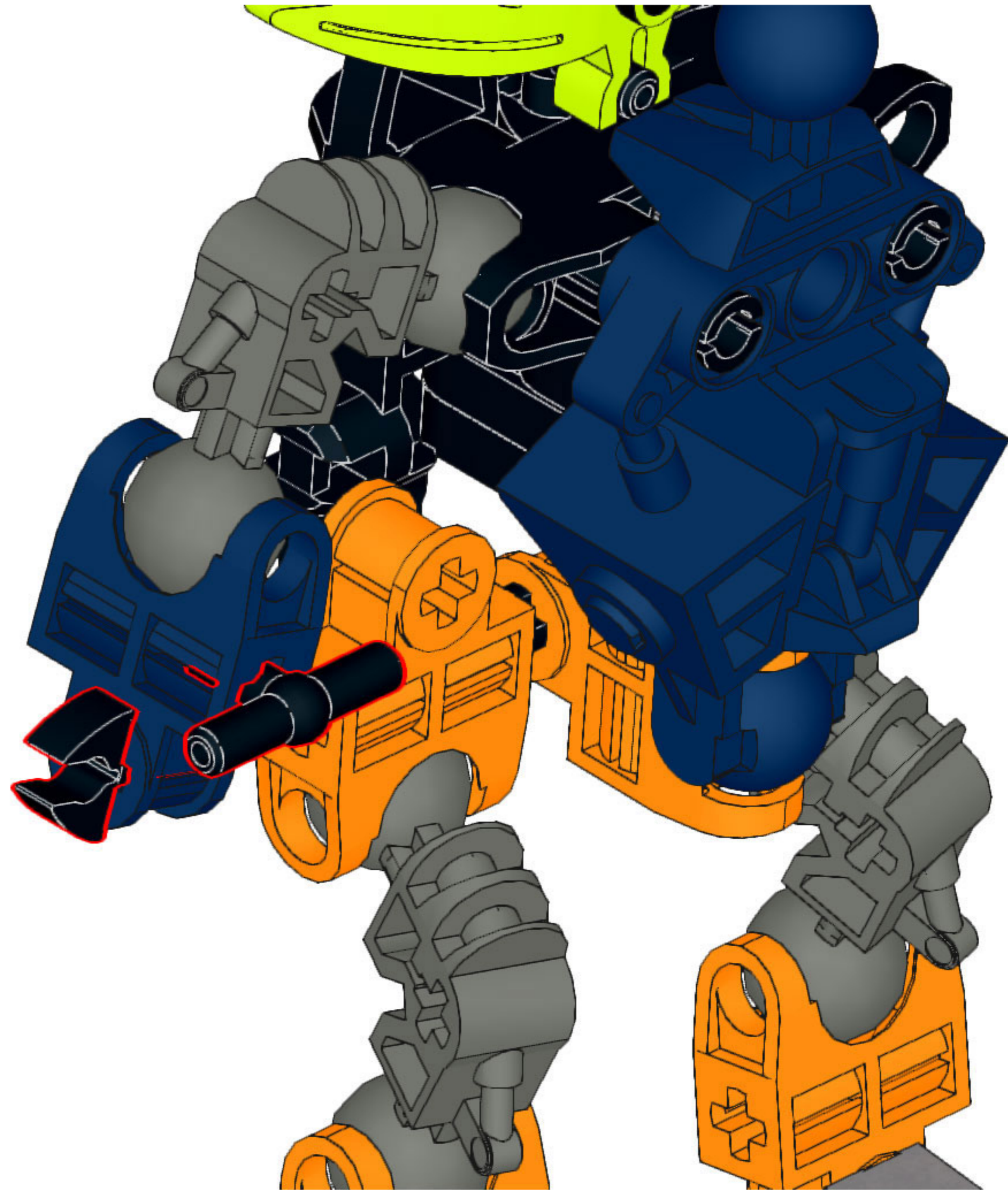
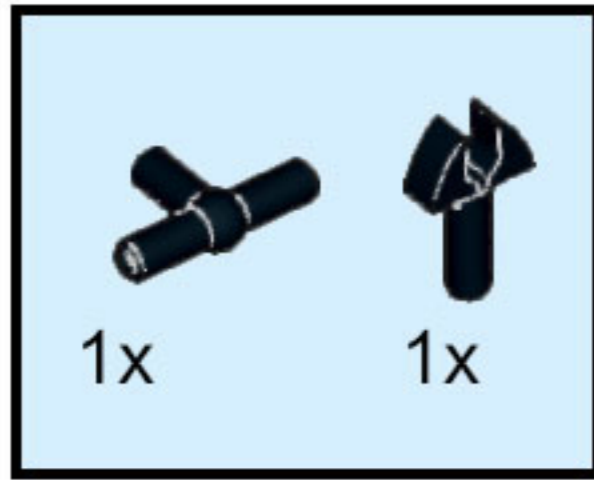

24

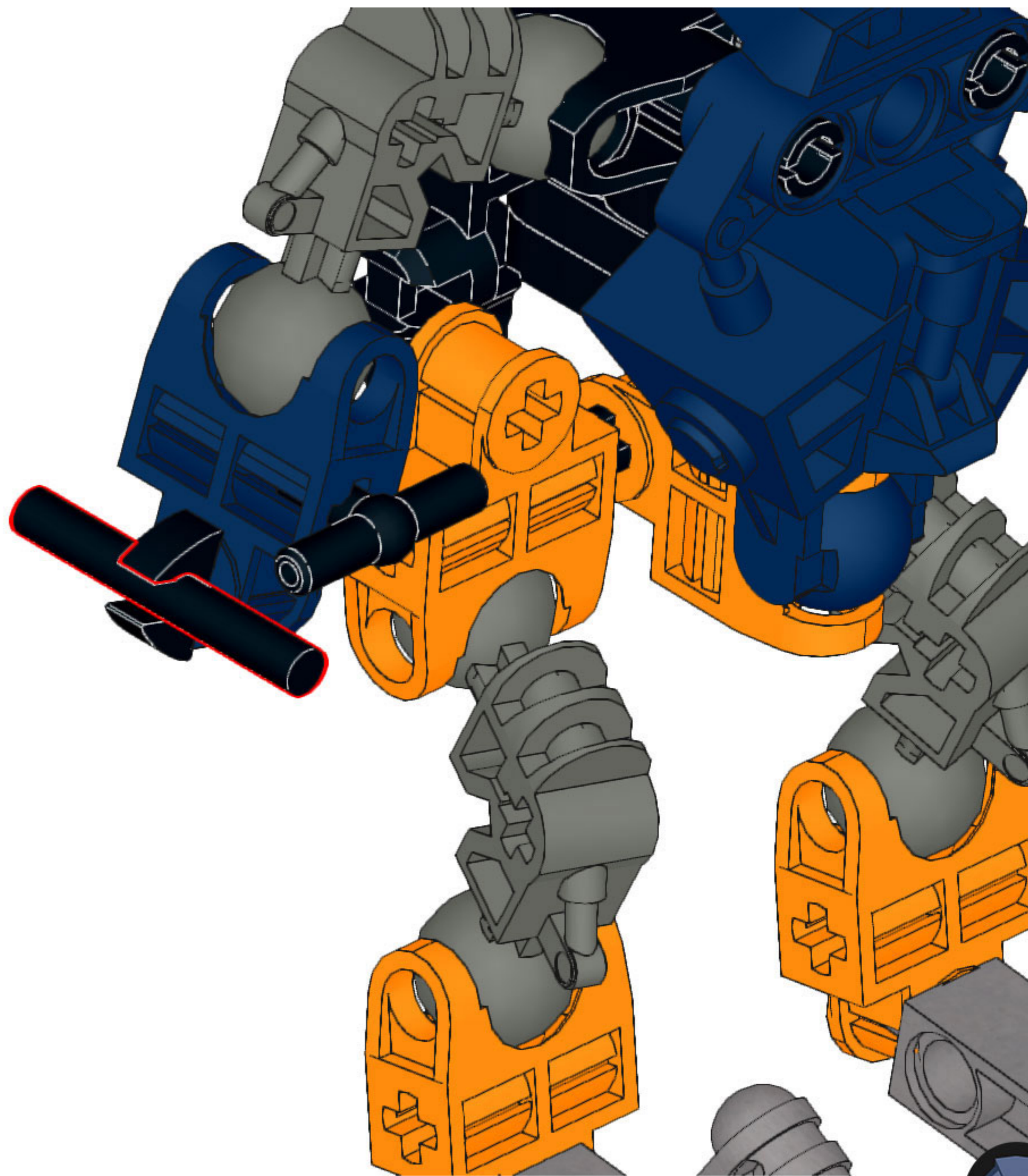
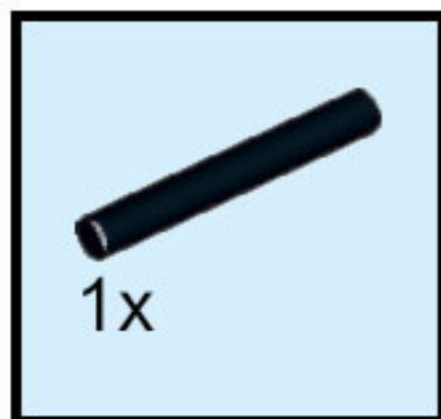

# 25

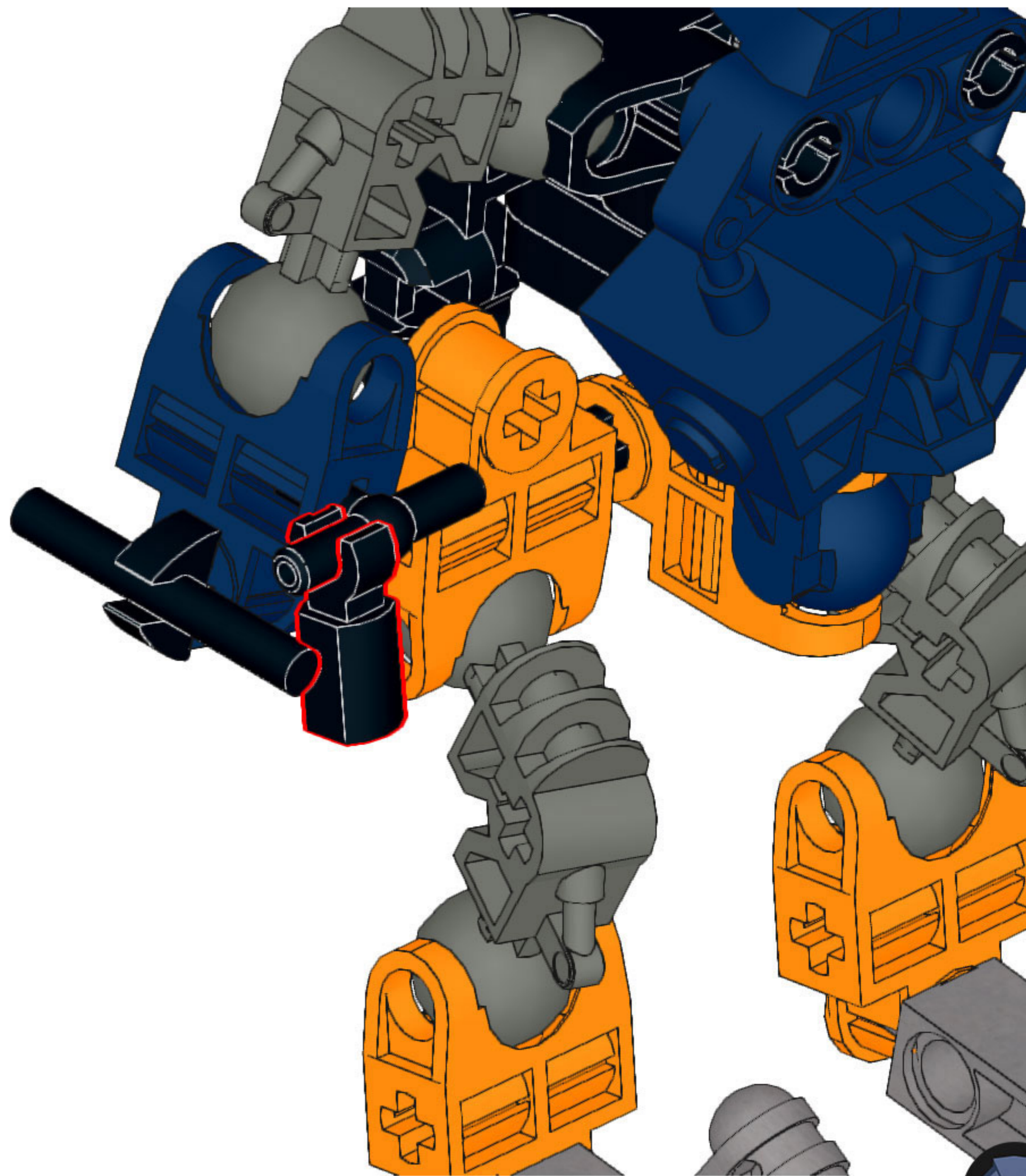

# 26

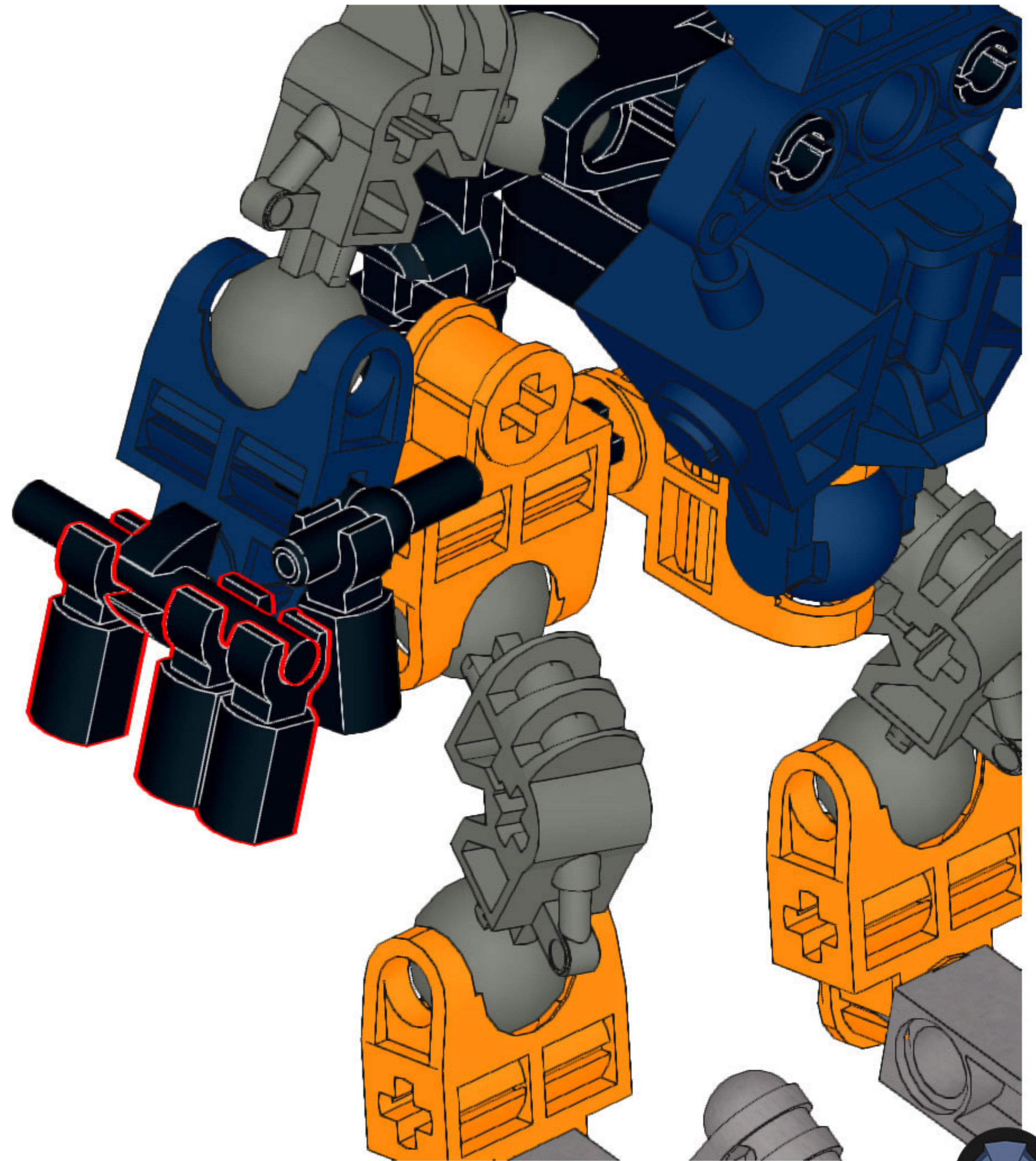

27

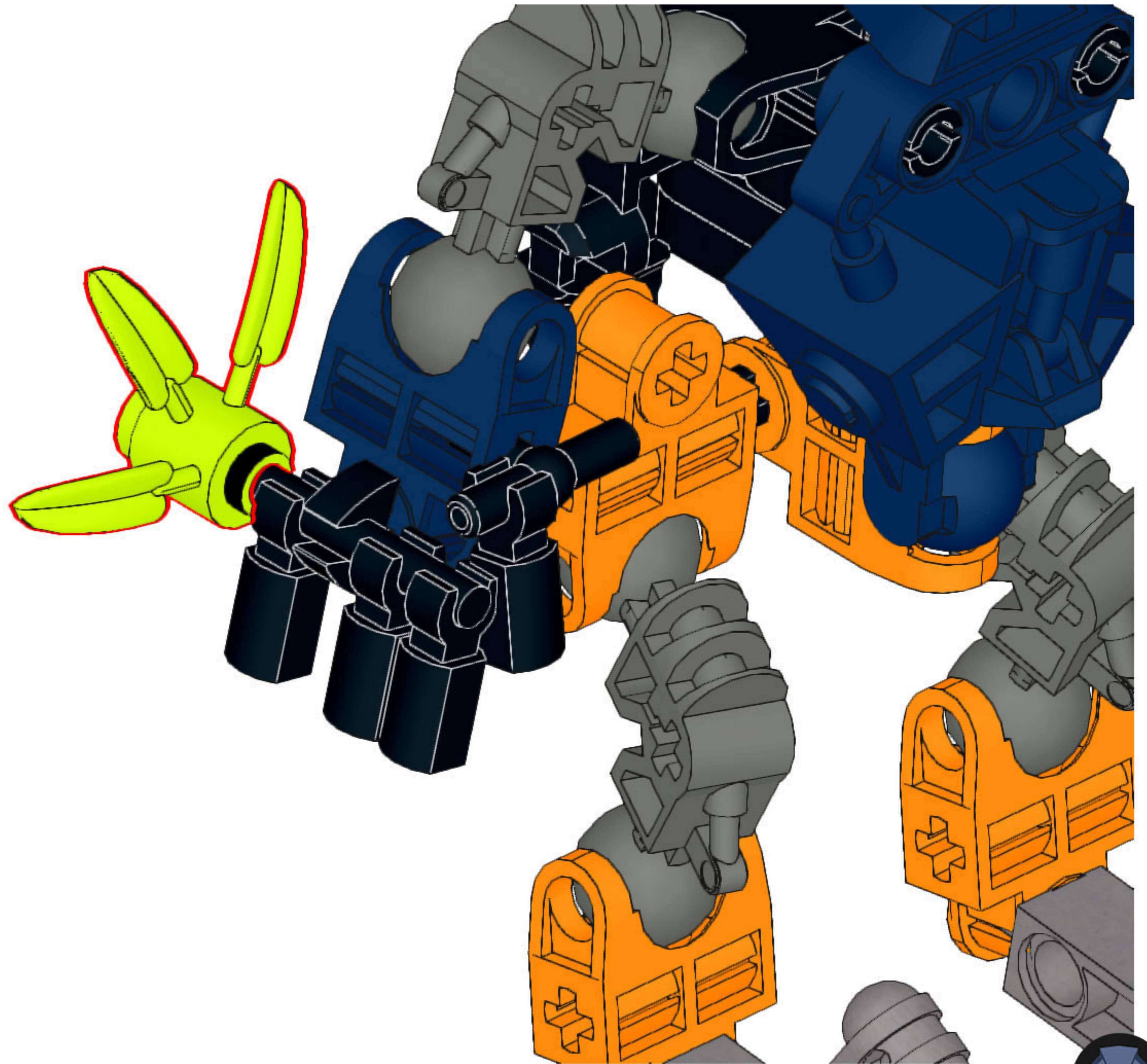
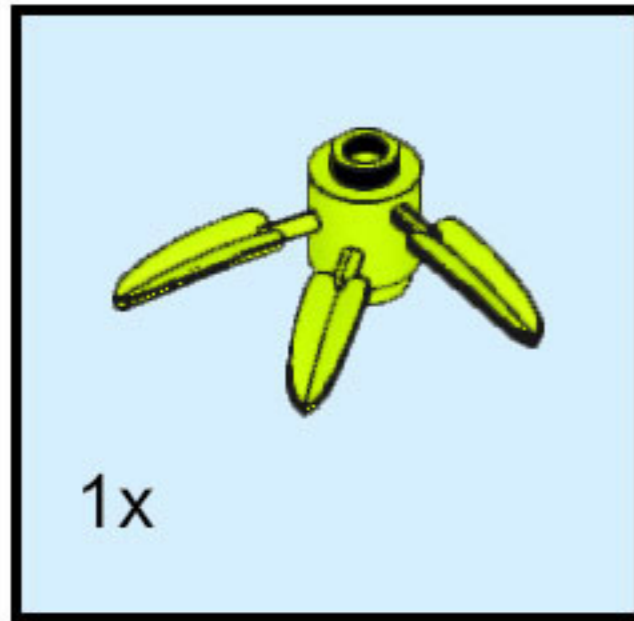

# 28

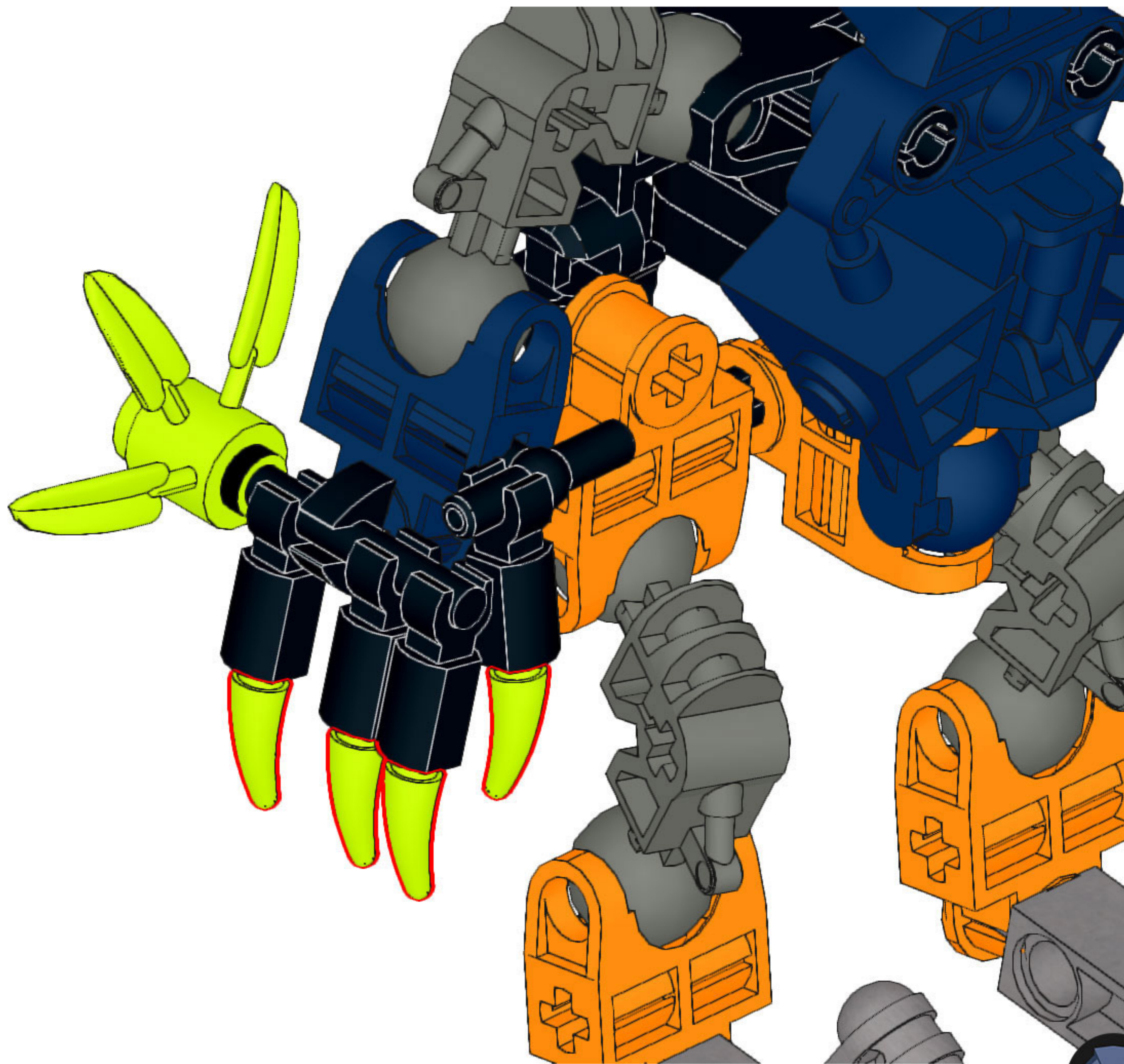
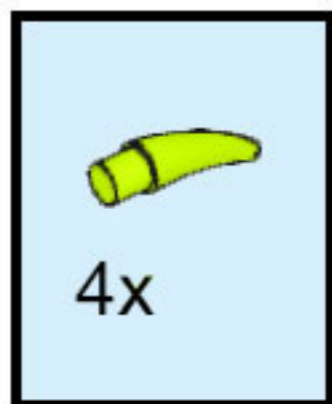

# 29

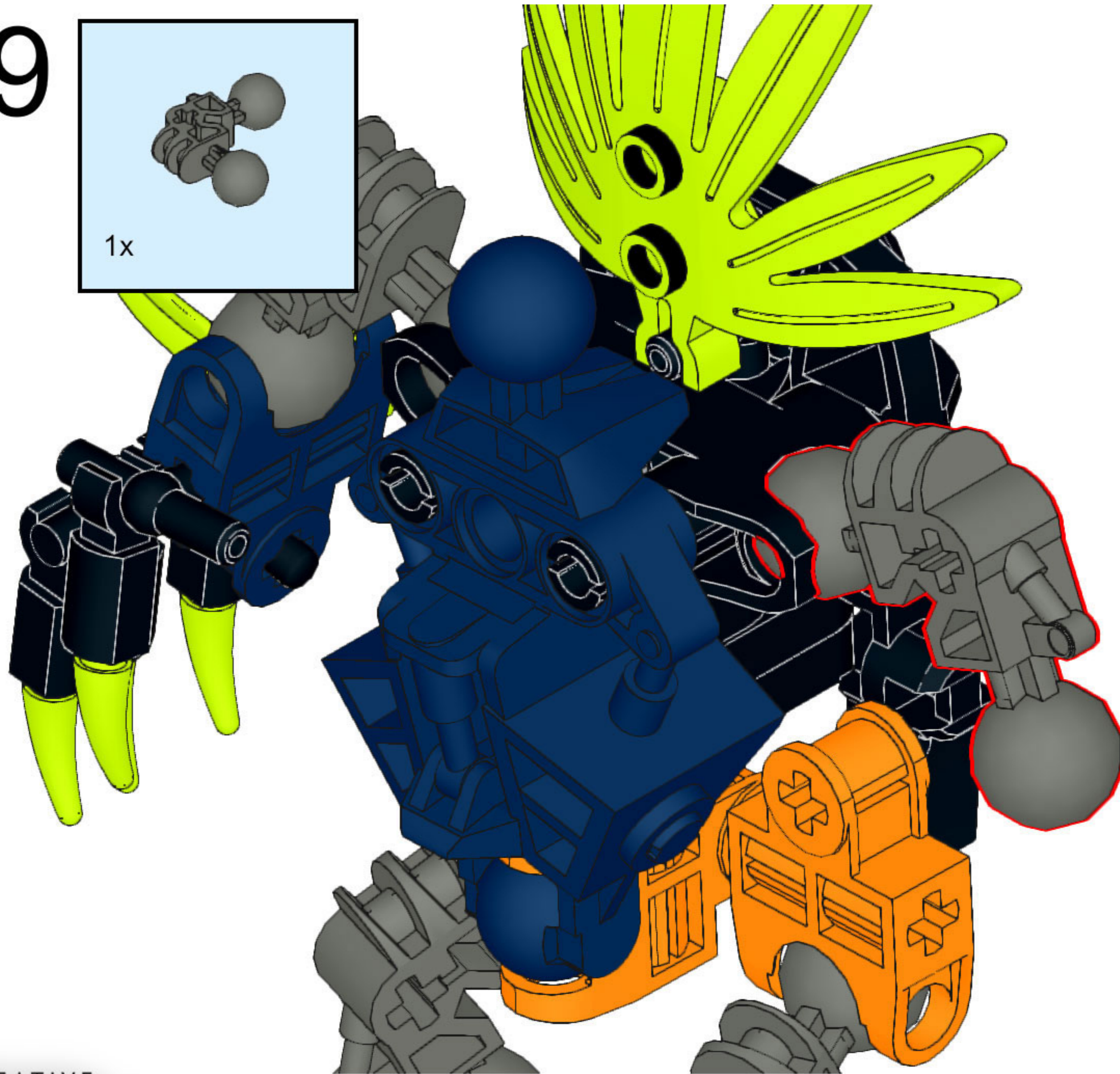
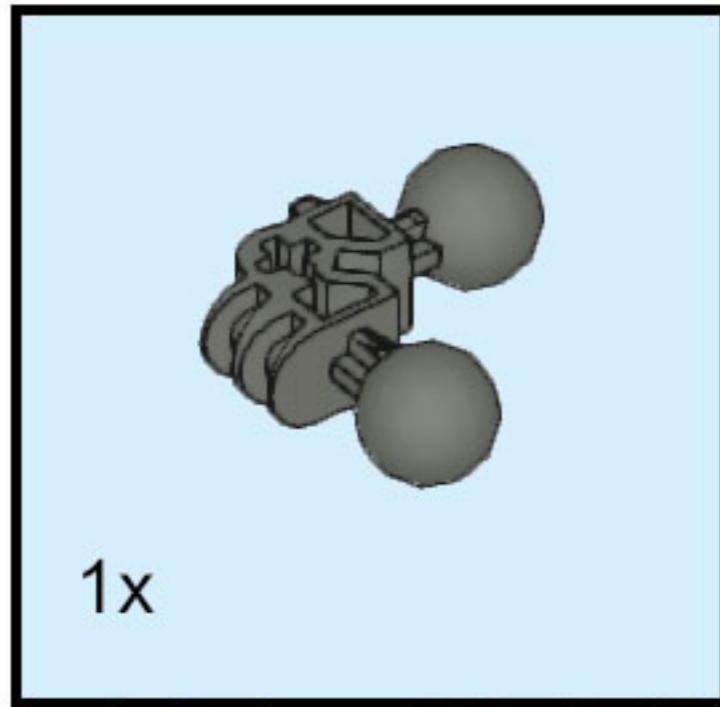

30

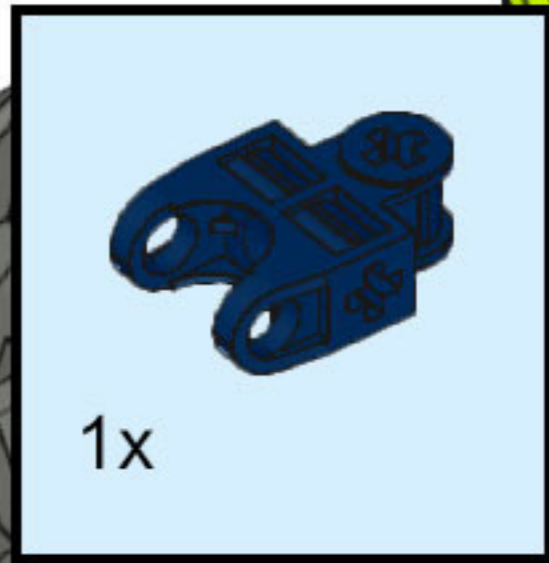

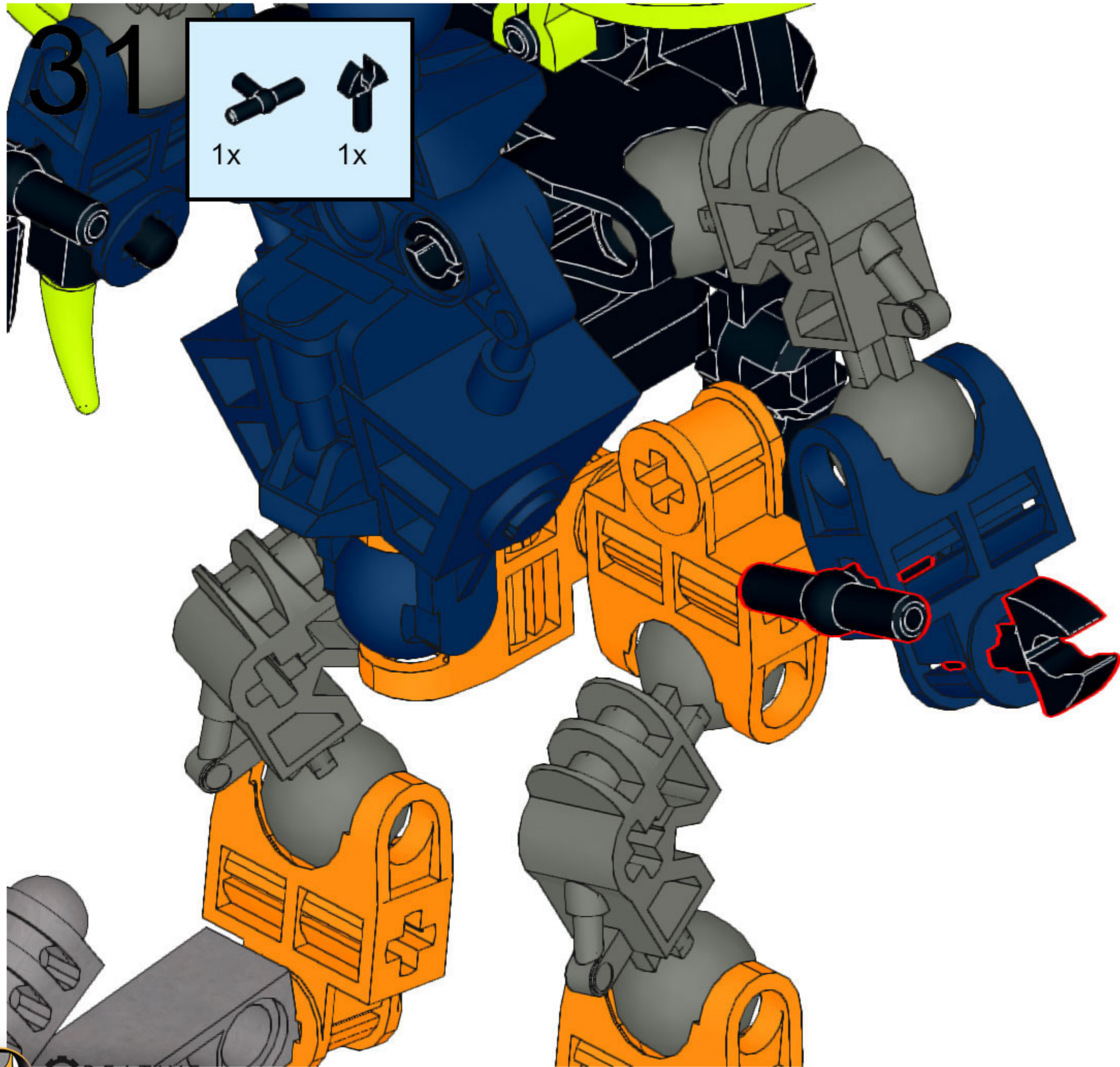

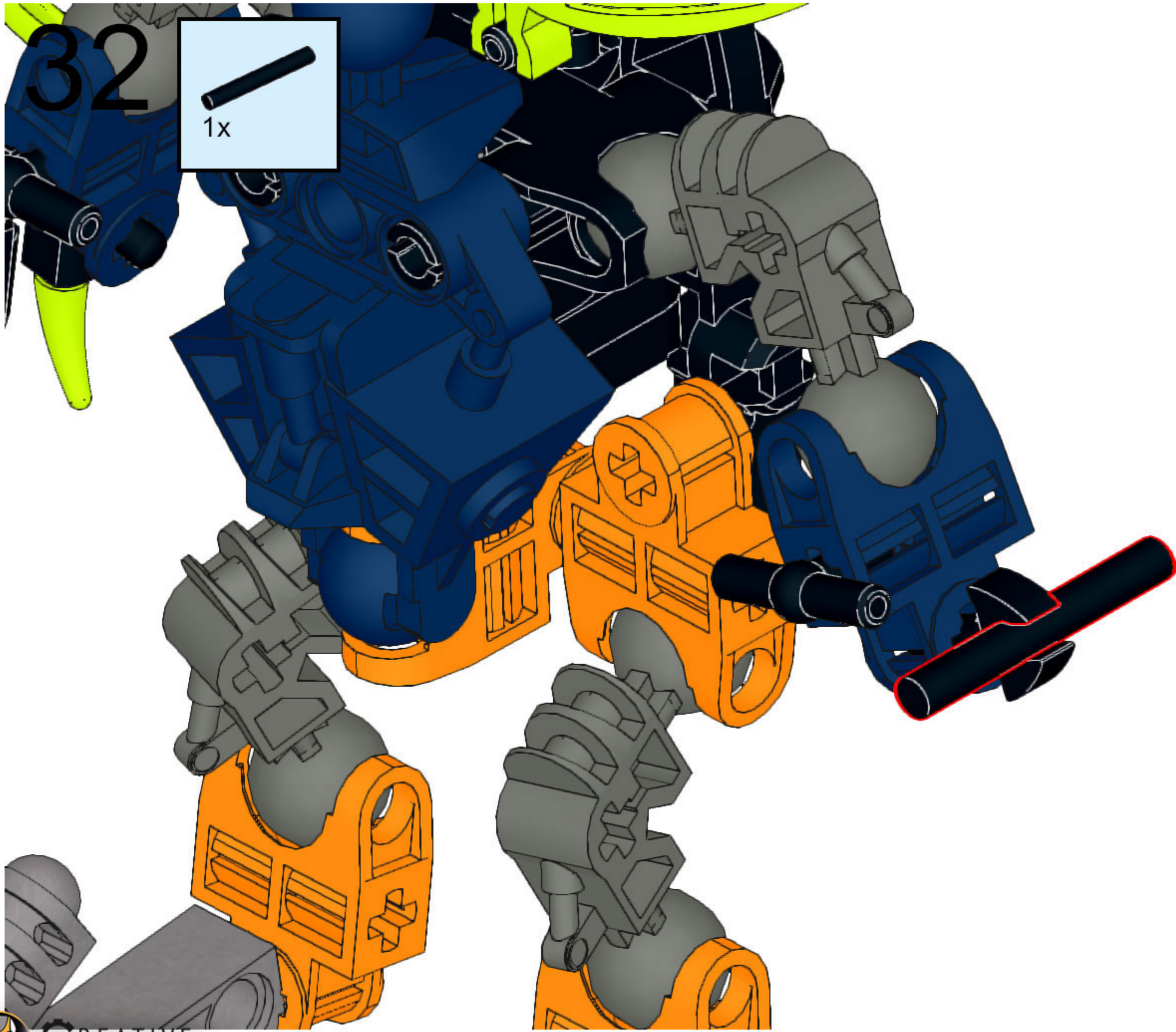

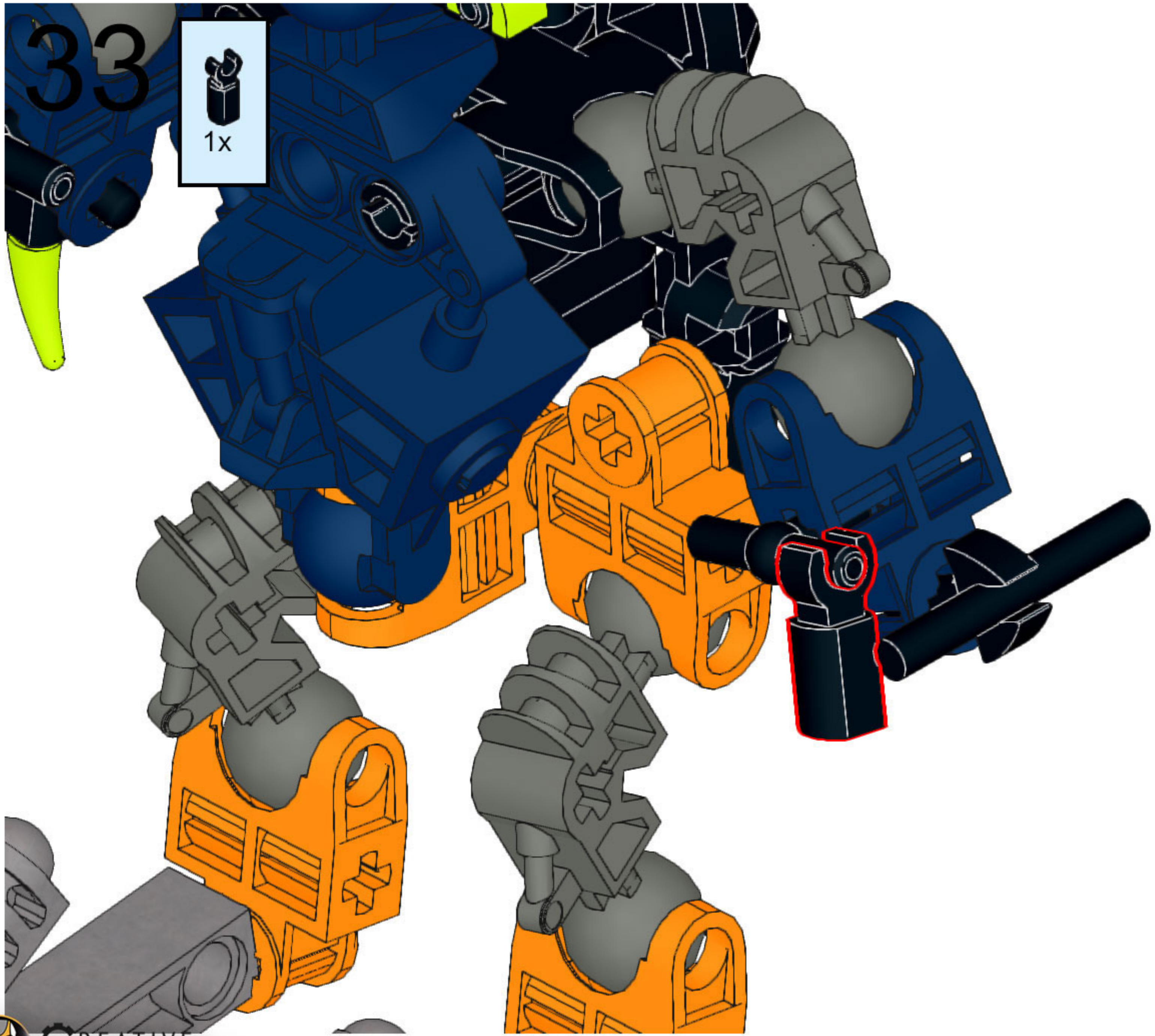

34

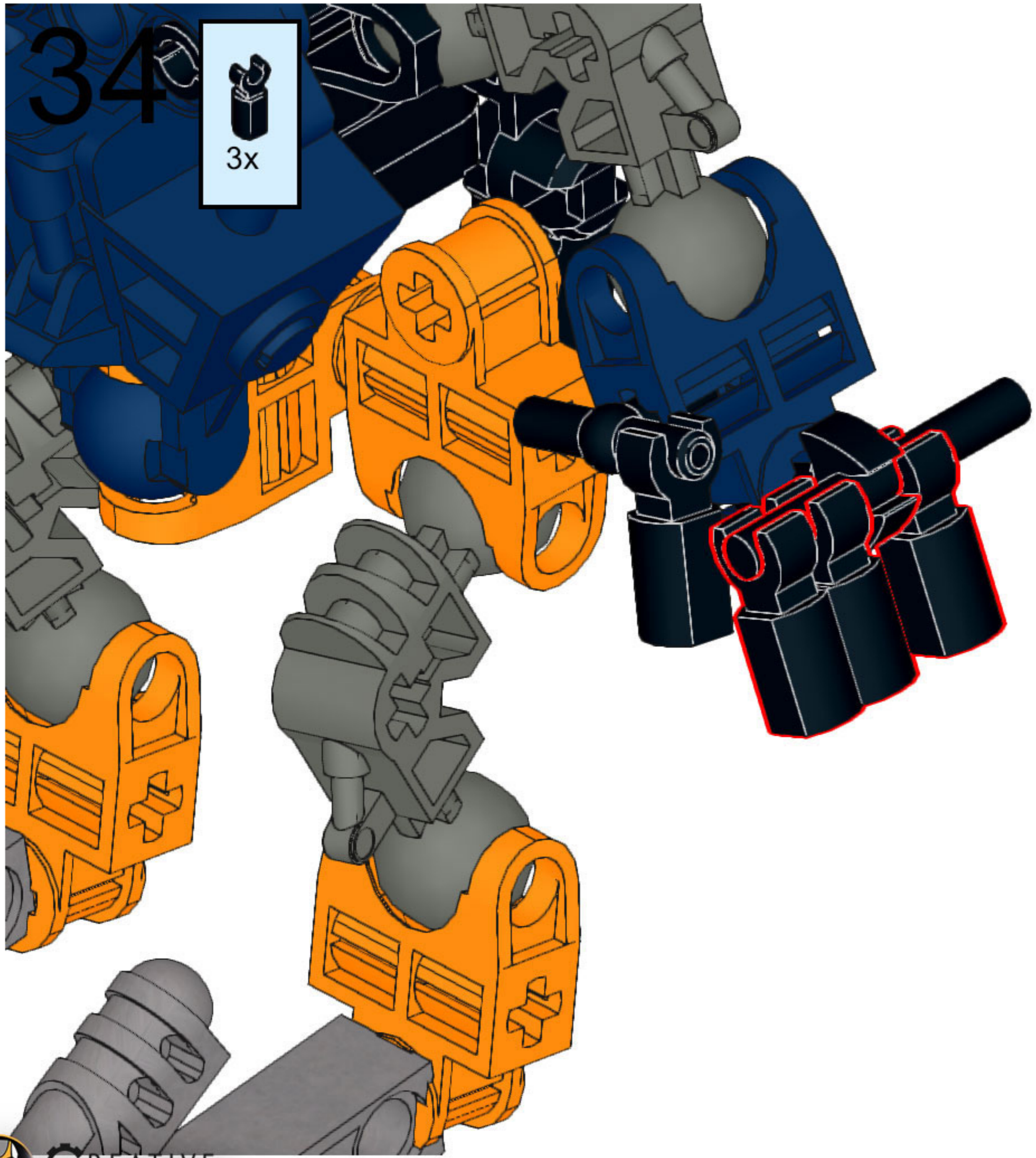

35

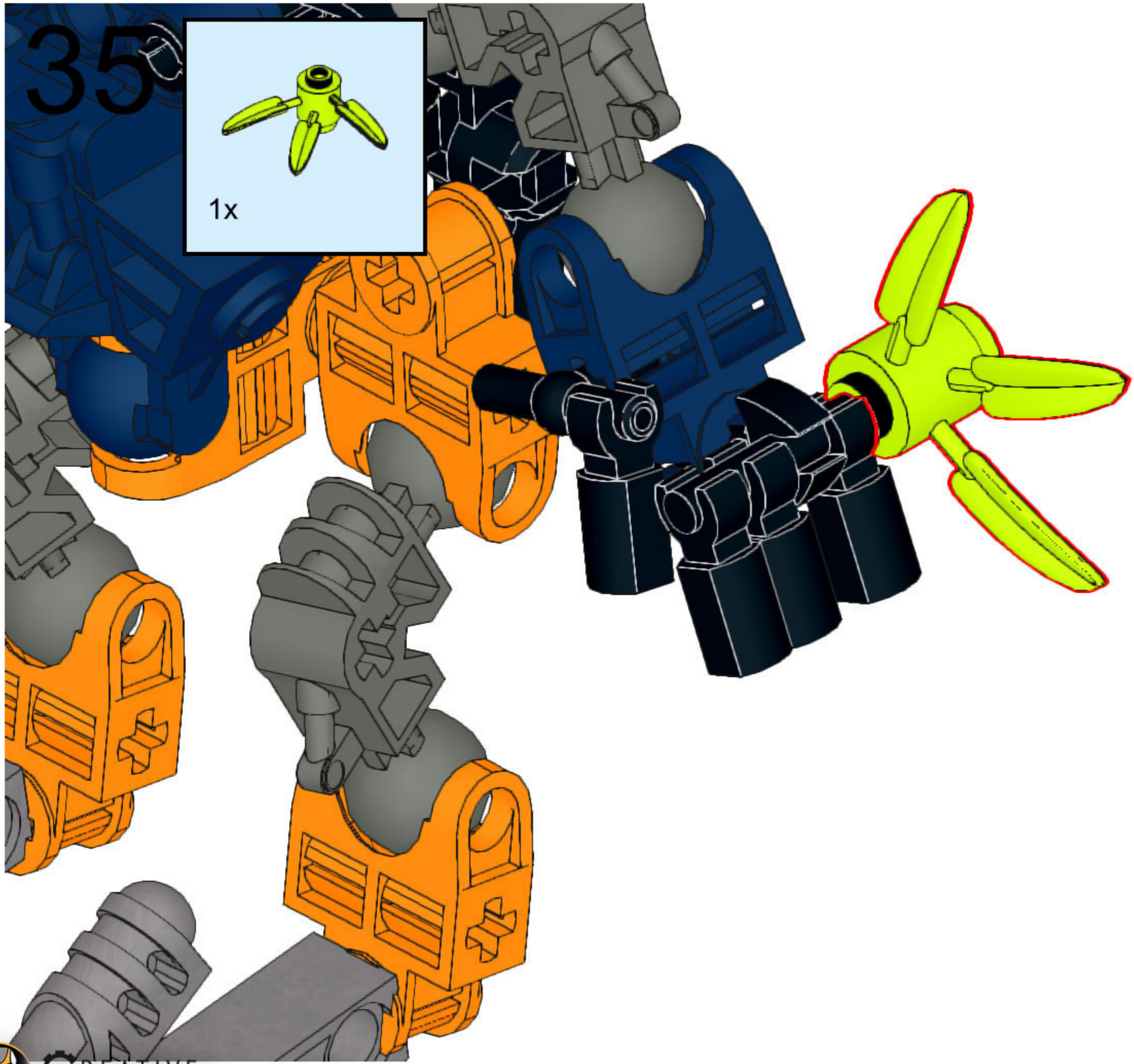
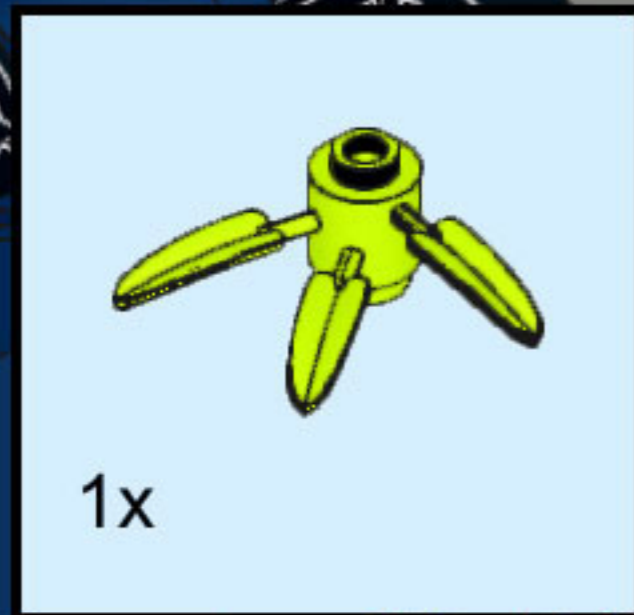

36

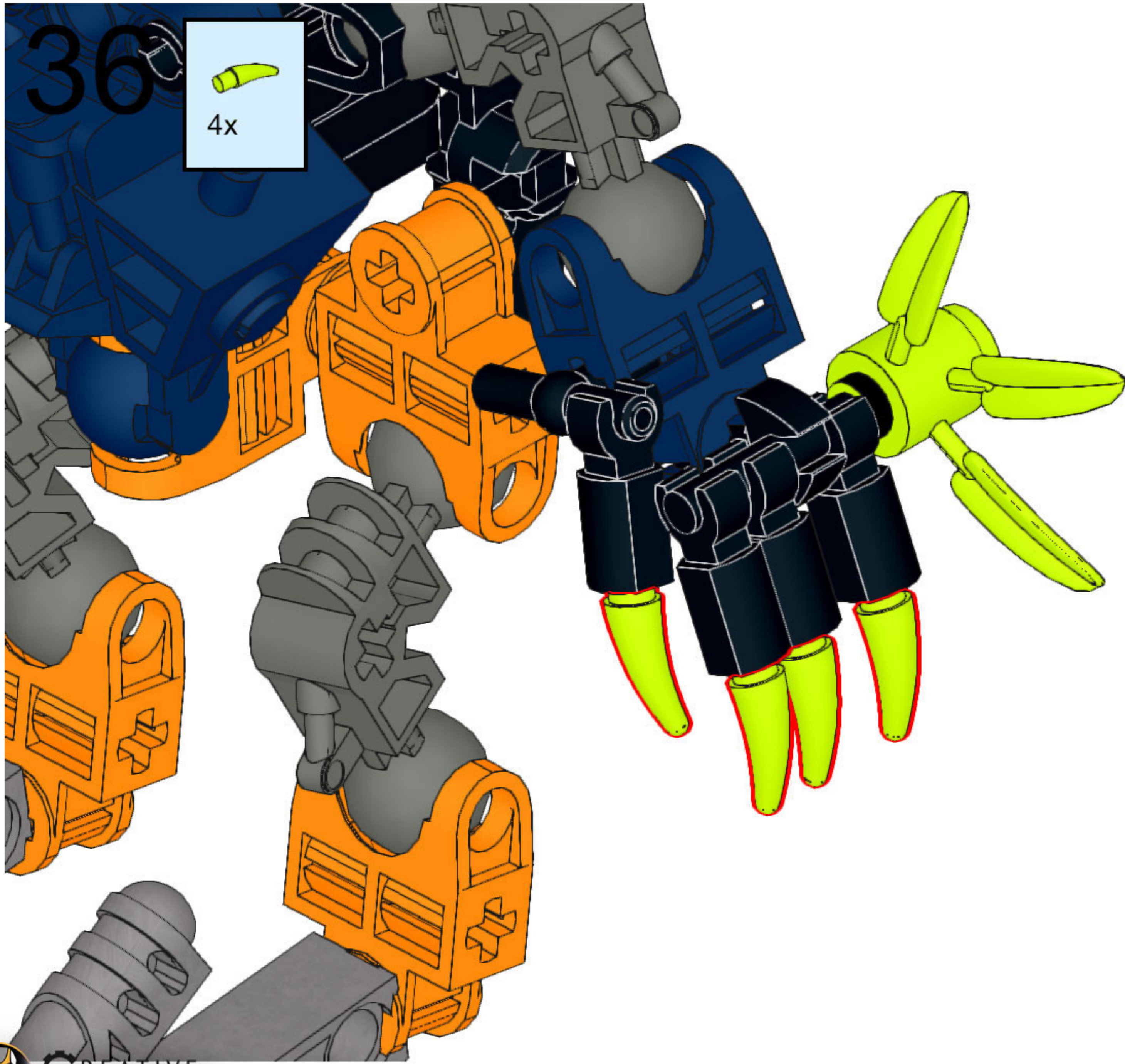

37

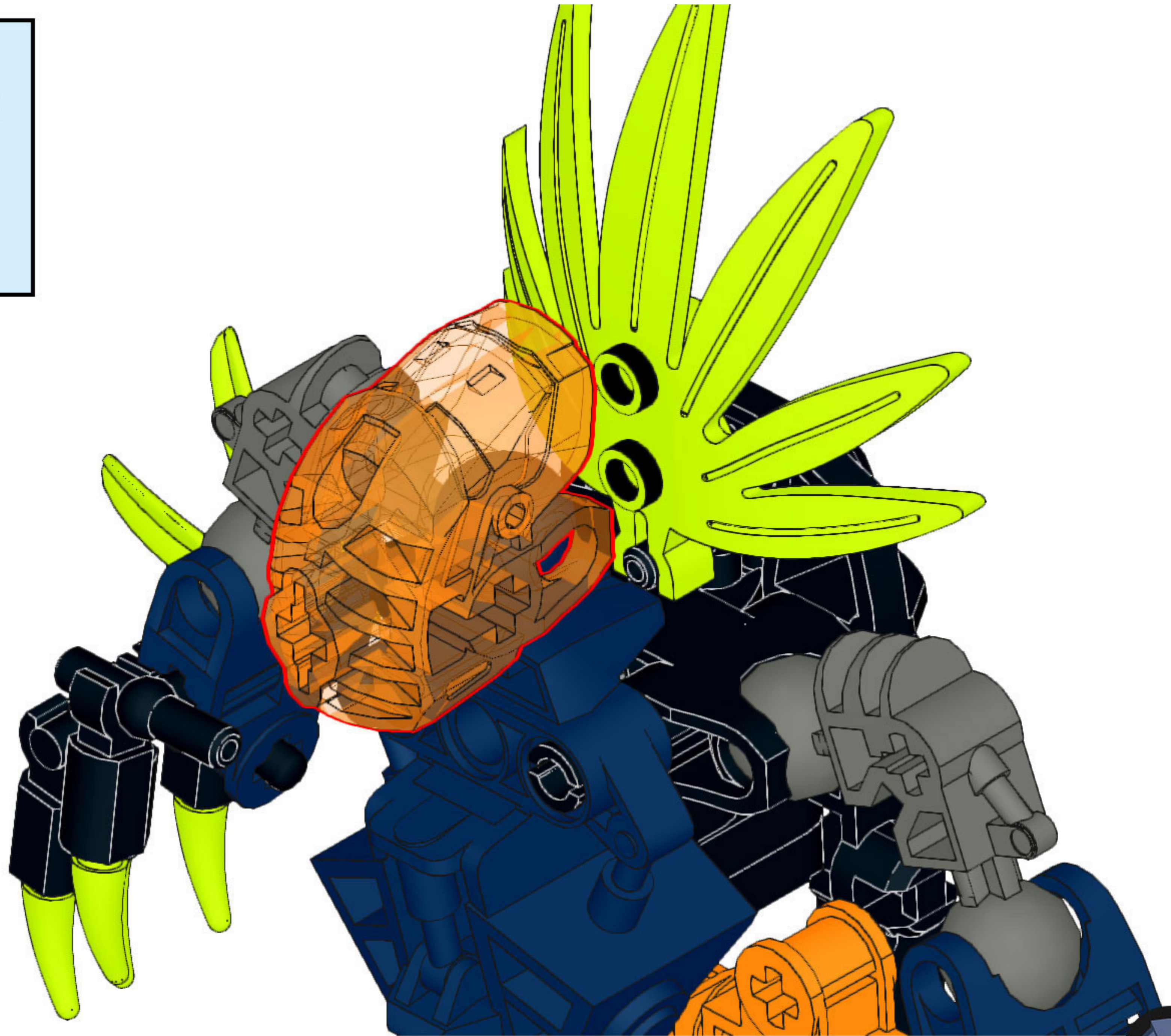
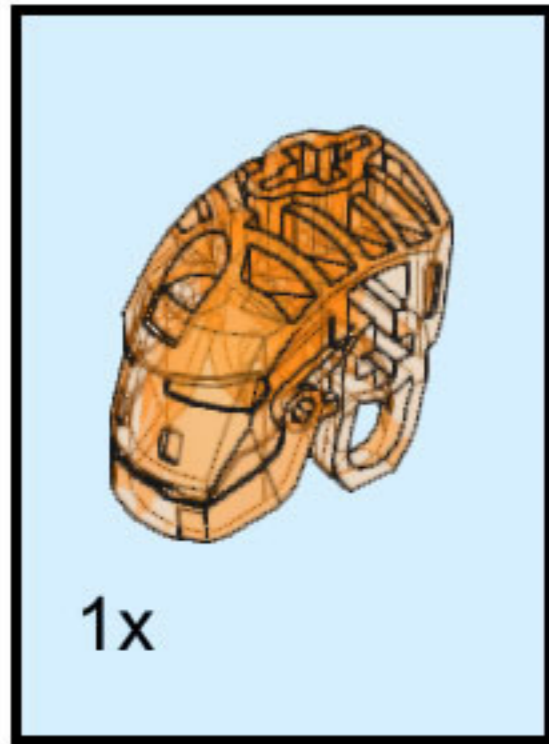

38

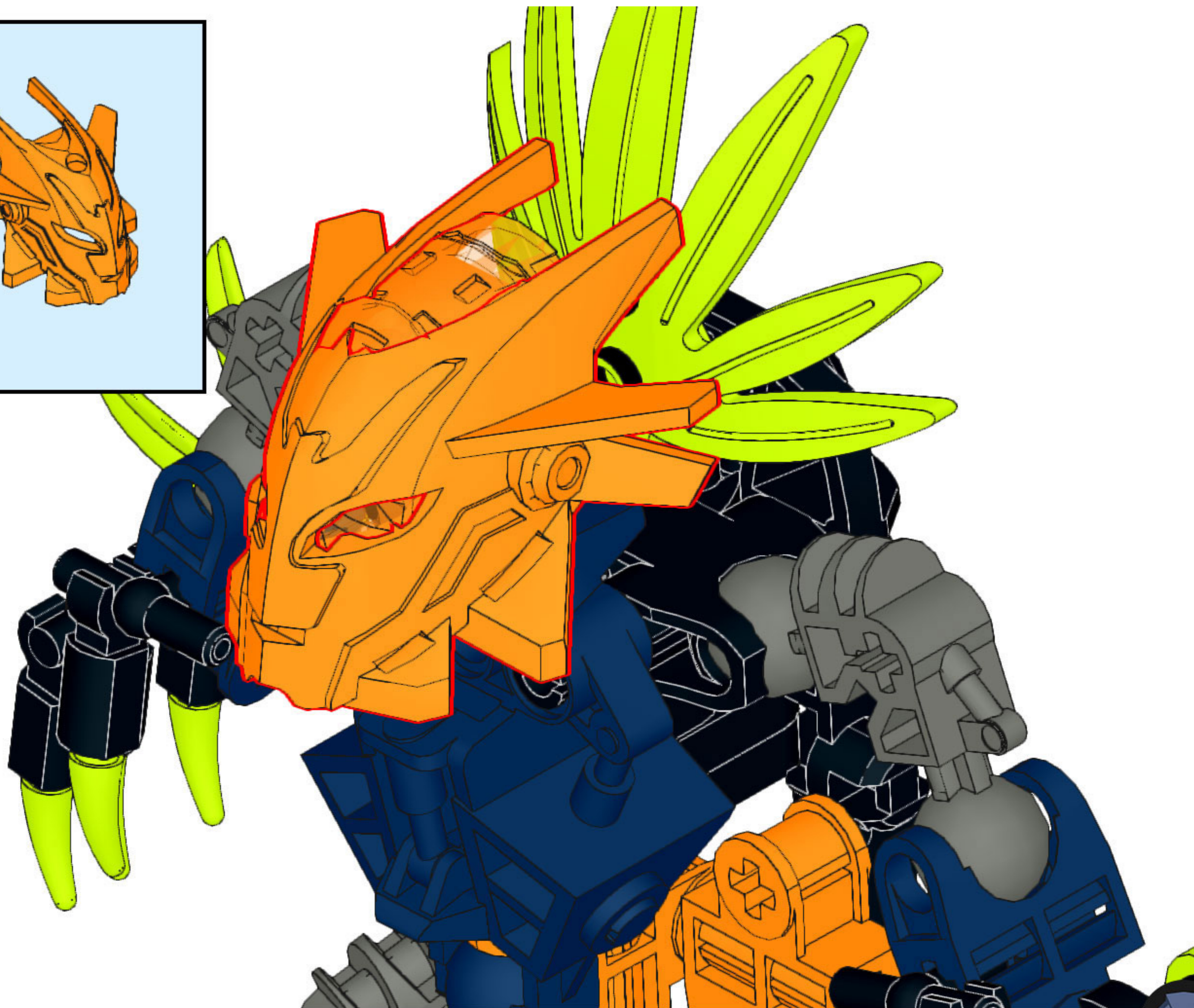
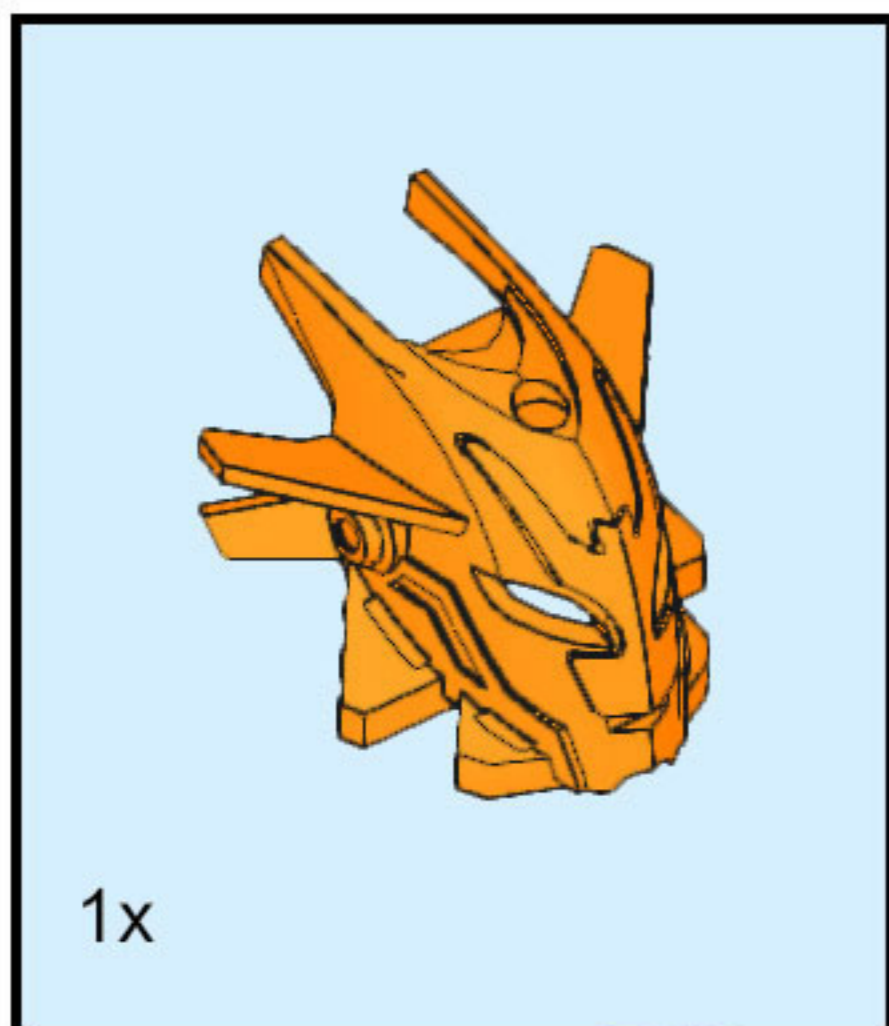

# 39

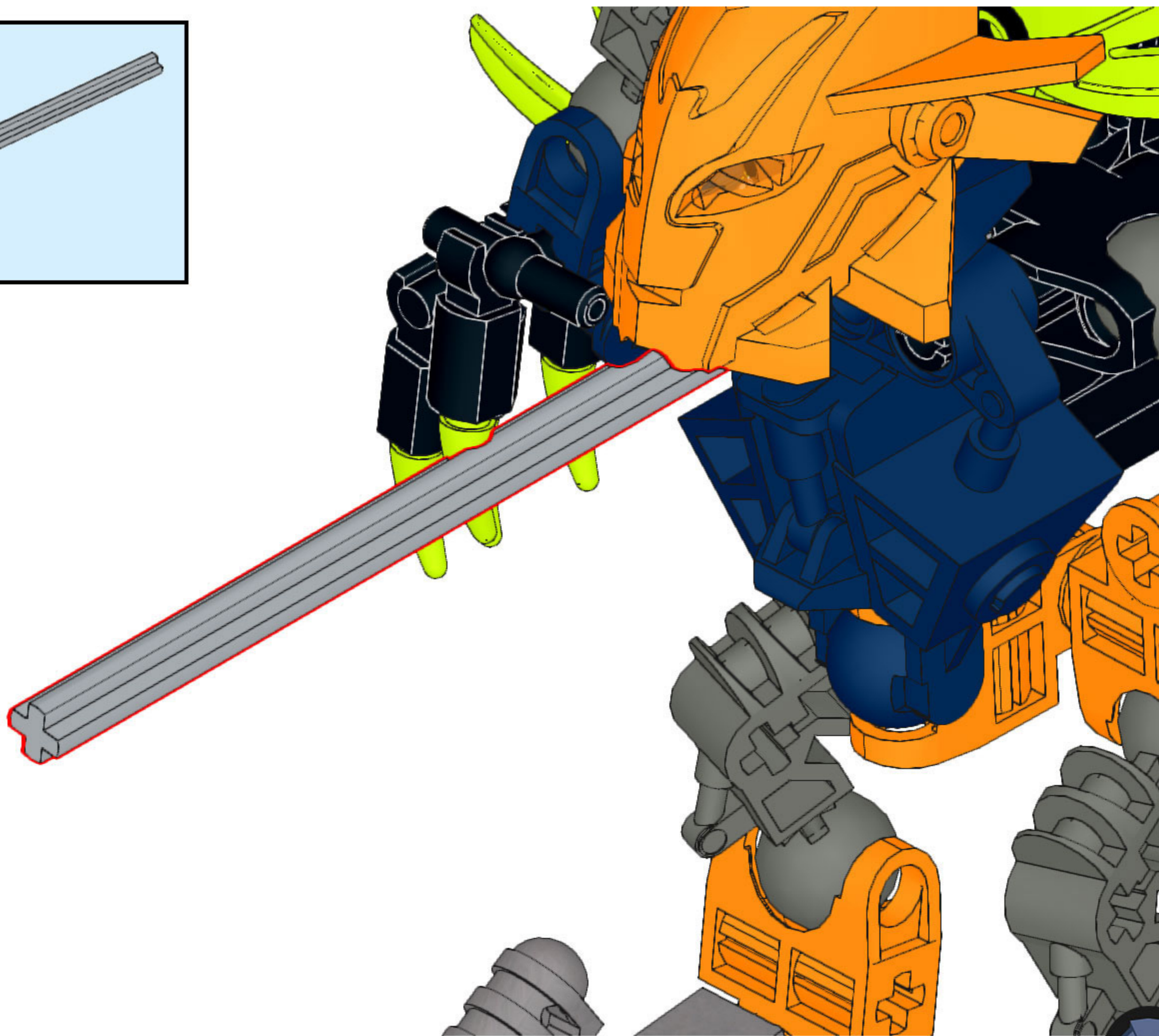
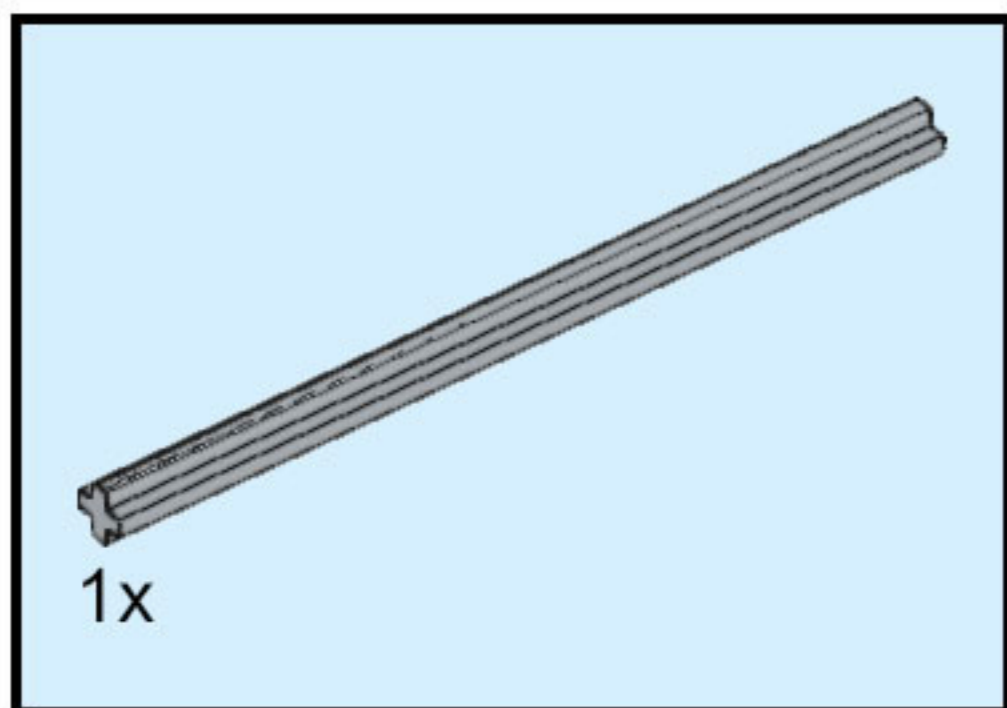

40

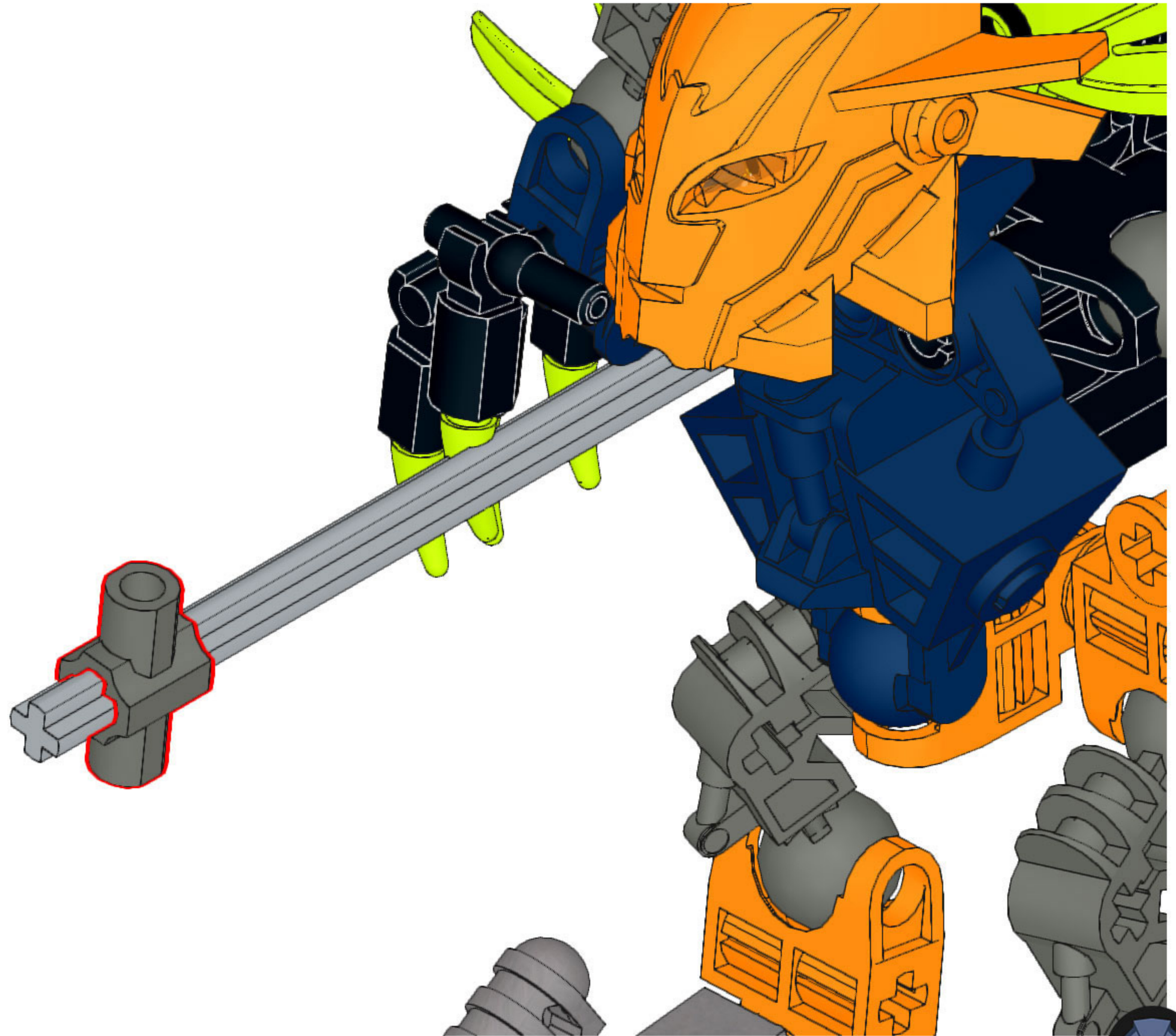
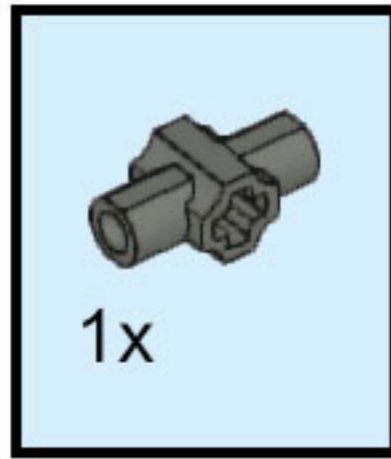

# 41

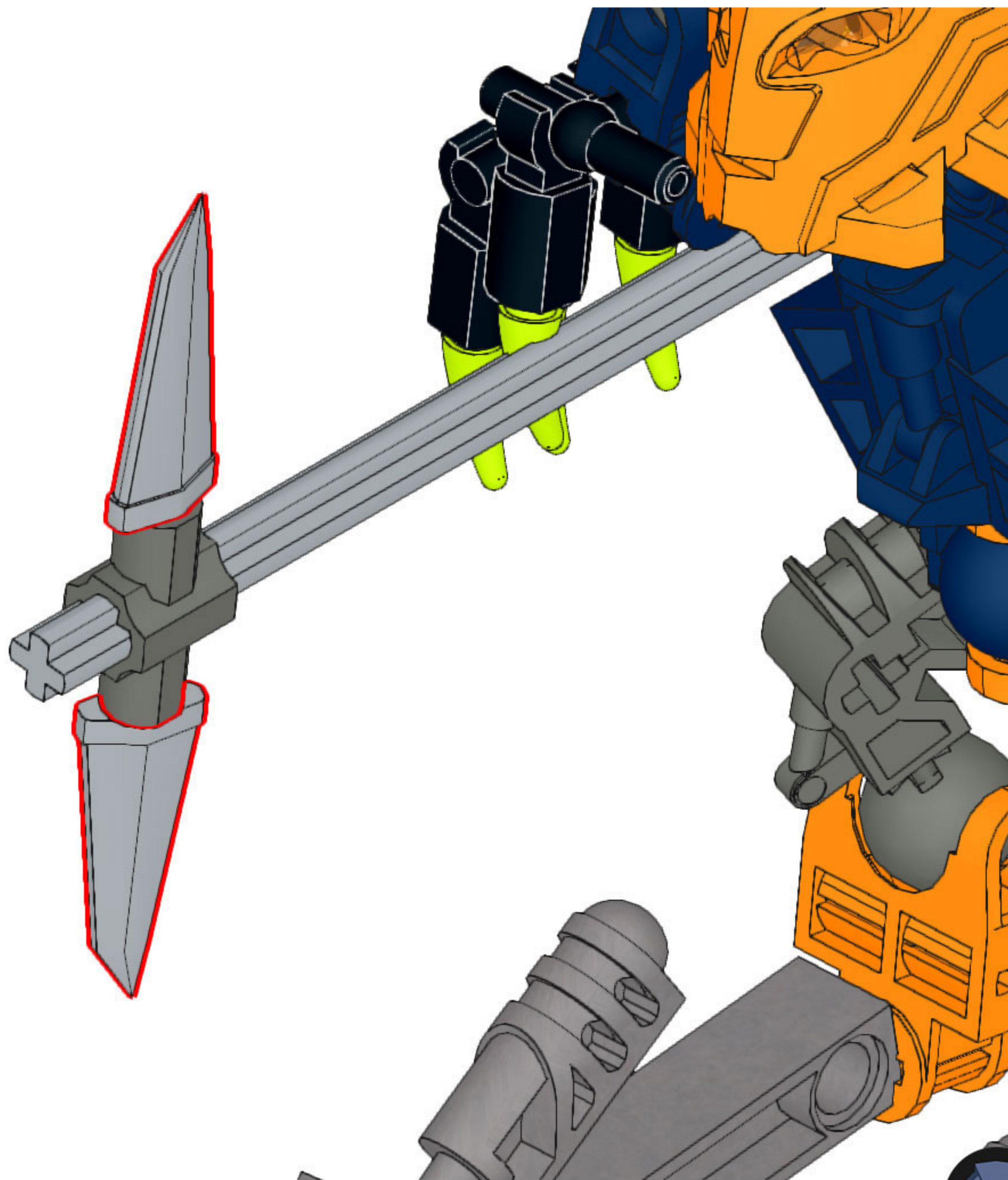
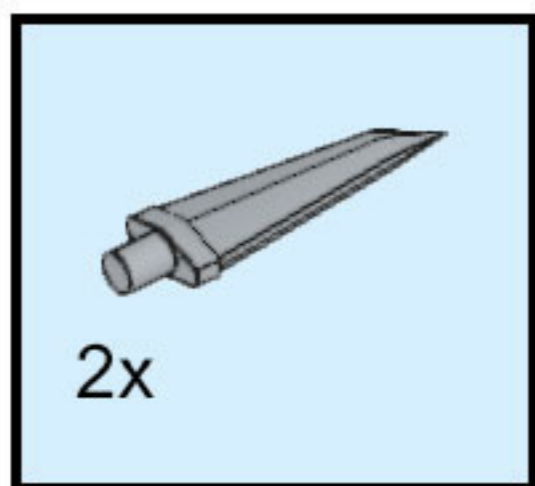

42

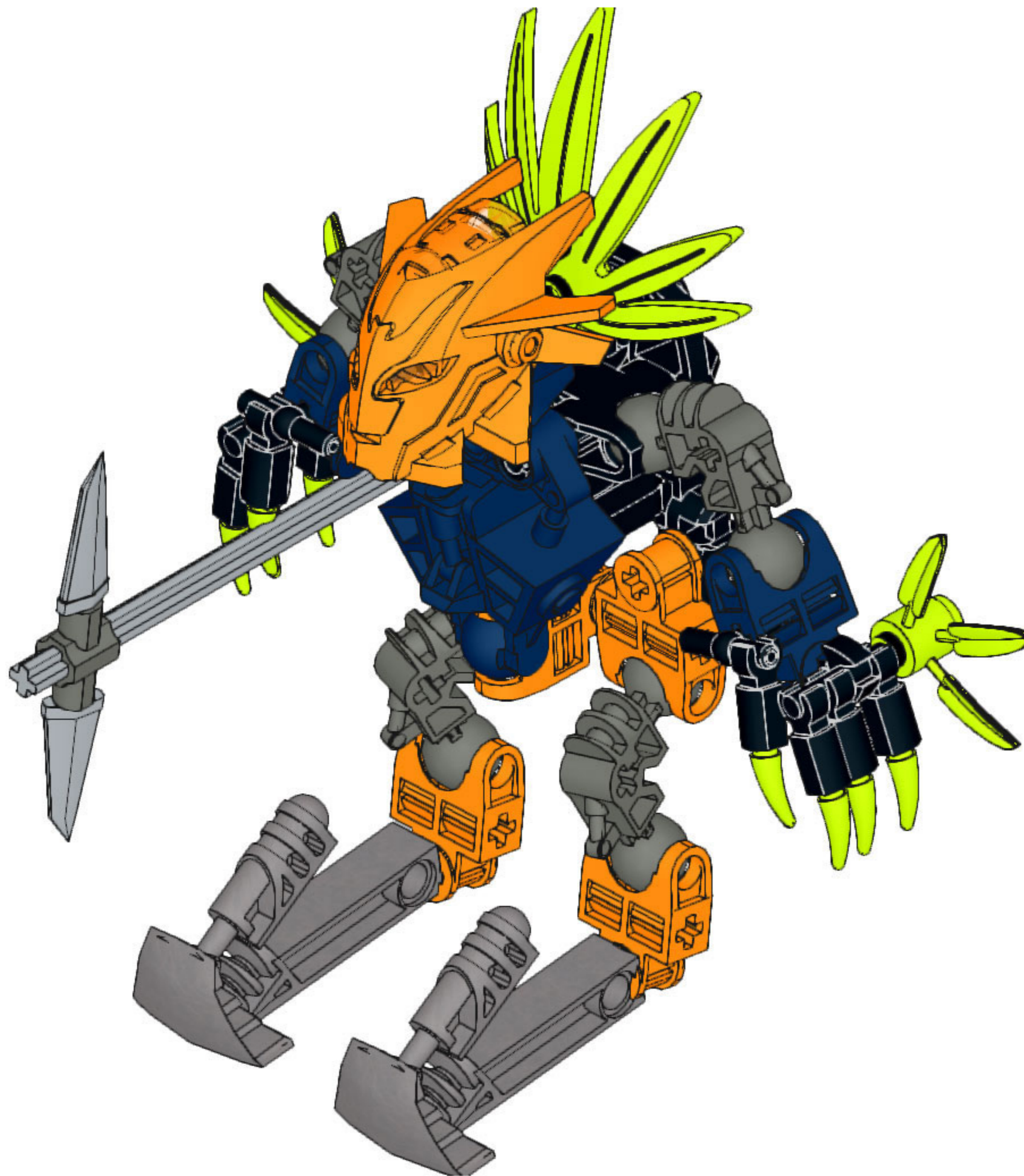

REMINISCENCE

EDENSANDERSART.COM/REMINISCENCE

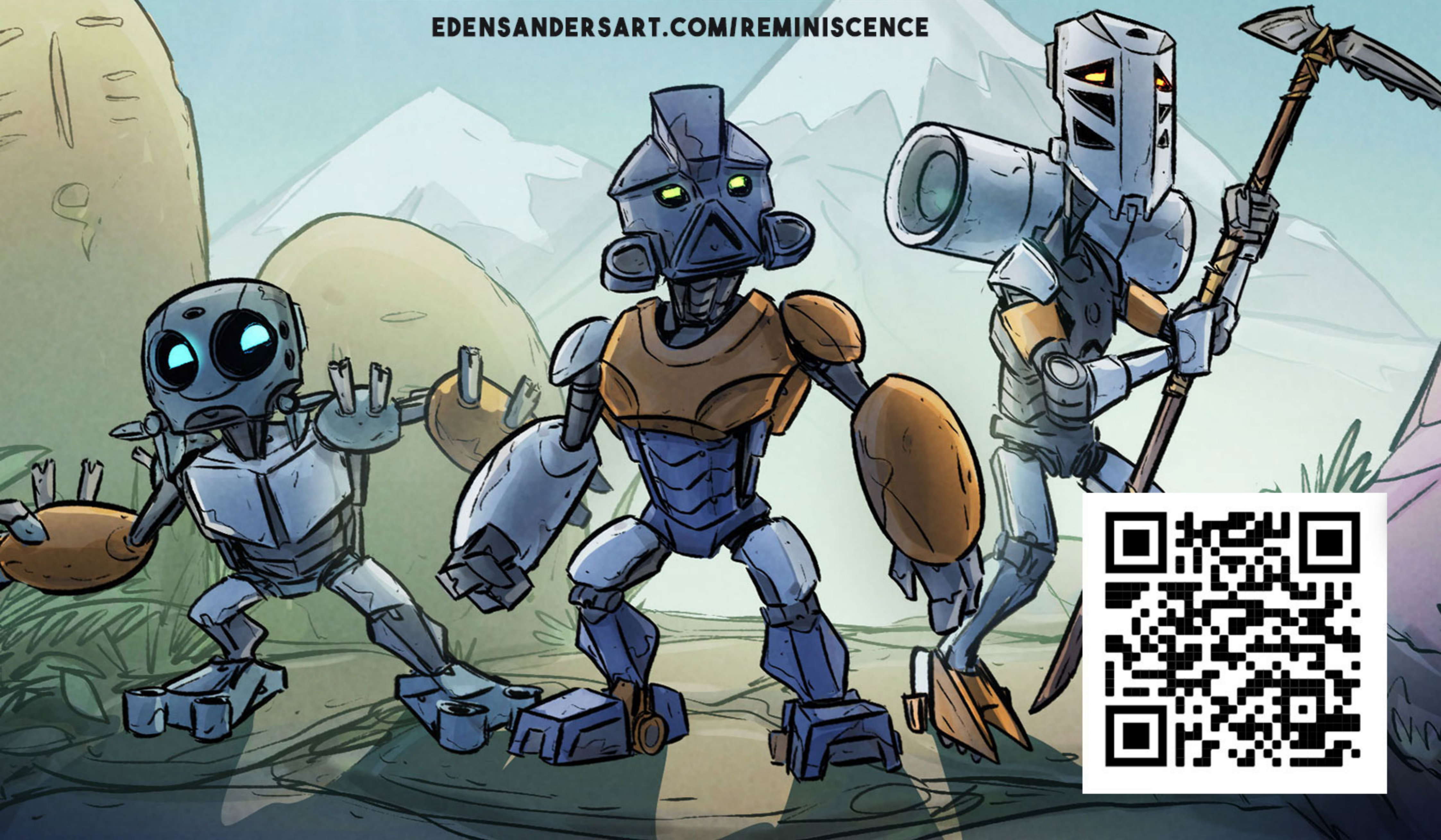

# BIONICLE

threadless



DRESS  
TO IMPRESS

[HTTPS://CREATIVEMECHANICS.THREADLESS.COM](https://creativemechanics.threadless.com)

